



Installation handbook of the EXV cable

1. Installation steps:

- (1) Making the cable terminal through the Cable-Cross Loop (Fig.1), and then winding the cable on the magnetic ring for three times(Fig.2), at last inserting the terminal into a corresponding slot(see circuit diagram).
- (2) Using bundles to fix the magnetic ring is required. It's also need to insert the bundle into the reserved hole on the control box.
- (3) Fixing the cable with the wire clamp, and tightening the Cable-Cross Loop.

2. Installation requirements:

- (1) Ensure that the cable in the control box is in a relaxed state, and both the joint of terminal and the fixed place of magnetic ring are all not under a stress.
- (2) Ensure that the cable sheath port is located in the control box in order to prevent the rain.

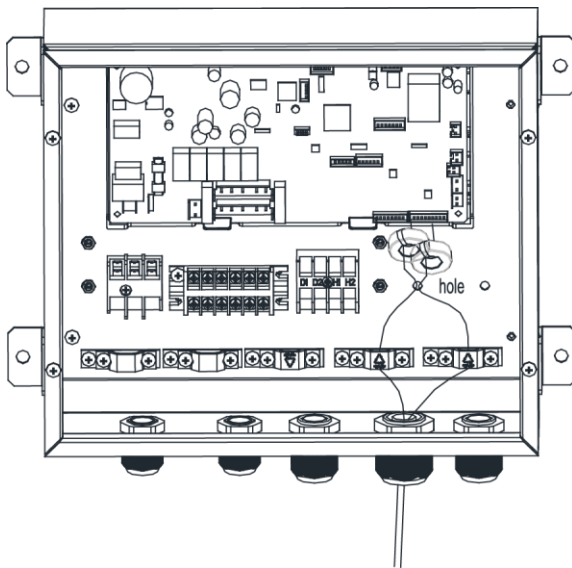

Fig.1

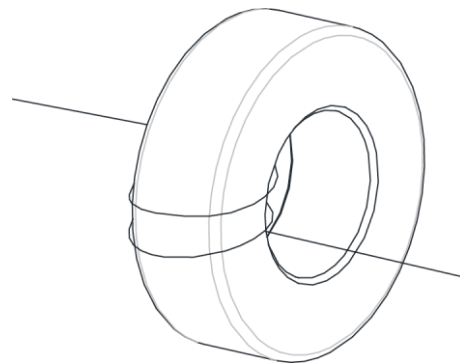

Fig.2

The quantity of expansion valve coil is determined by the actual number of fittings.



66129926960