

Energolux

TECHNICAL MANUAL

Commercial Air Conditioners (R410a , 50Hz)

SAD80D1-A
SAD100D1-A

SAU80U1-A
SAU100U1-A

 Designed in
Switzerland

www.energolux.com



Contents

Part 1 General description	3
Part 2 Universal outdoor unit	16
Part 3 Trouble shooting.....	34
Part 4 Controller	63
Part 5. Sensor resistance table	66

Part 1 General description

Series	Picture of the indoor unit
High ESP Duct	
Universal outdoor unit	

High static pressure duct type

1. Feature.....	5
2. Specfication	7
3 Capacity amendment.....	8
4. Dimension	10
5 Electrical wiring and connection.....	11
6. Fan performance.....	12
7. Installation.....	12

1. Feature

Duct type air conditioner (Cooling-only or Heat pump), named for the duct can be installed to connect with air outlet and inlet. According to different ESP, it divides into Low ESP Duct type (12~30Pa), Medium ESP Duct type (50~80Pa) and High ESP Duct type (higher than 80Pa). The series of products static pressure for 150Pa High Duct type.

Application occasions:

Small super market, hotel, restaurant, office, meeting room and so on.

Features:

- ◇ ESP range is optional, application place varies, ESP can reach 150Pa suits 6.5m super high ceiling air supply;
- ◇ According to place designing different air-outlet, The type of air supply and air return was set flexibly and appropriate. The No matter where you are, it will provide comfortable for you.
- ◇ Conceal design, the unit is installed inside of ceiling, doesn't take room space.
- ◇ With Setting or Auto two operation modes, multi speed wind, makes you feel more comfortable;
- ◇ Auto restart;
- ◇ Standard wired controller and optional remote controller;
- ◇ Special insulation design, achieves high heat insulation efficiency and no condensation on shell;
- ◇ units with low ambient temperature cooling function, which makes the unit can run normally on the condition that the ambient temperature falls down to -15°C;
- ◇ Failure automatic detection, if there is a failure, the indicator will flash and the failure code will display on the wired controller, the failure cause is easier to be found..

Function introduction

Function	Function item	SAD-D1-A	
		80	100
Protection	High pressure protection	●	●
	Low pressure protection	●	●
	Compressor overloading protection	●	●
	High exh. temperate protection	●	●
	Phase protection(Phase-loss, phase-reverse)	●	●
	Over-heating protection	●	●
	Anti-freezing protection	●	●
	Sensor failure alarm	●	●
	Failure code display	●	●
Comfort	Cooling	●	●
	Heating	●	●
	3-Speed	●	●
	Adjustable ESP	—	—
	Auto-restart	●	●
	Anti-cold wind	●	●
	Afterheat wind blowing	●	●
	Timing ON/OFF	●	●
Operating	Time display	●	●
	Operation mode display	●	●
	Fan speed display	●	●
	Defrost display	●	●
	Timing ON/OFF display	●	●
	Wind angle display	—	—
	Sleeping mode display	●	●
Running	Auto start	●	●
	Dehumidifying	●	●
	Auto defrost	●	●
	Ventilation function	●	●
	Low ambient temperature cooling	—	—
Health	Washable air filter	●	●
	Fresh air interface	—	—
Installation	Left/right drainage	—	—
	Left/right pipe connection	—	—
	Down/back air suction	—	—
	Installation indicating board	—	—
	Two kinds of static pressure adjustable	—	—

Note: ● means have this function

— means don't have this function

2. Specification

Model	Indoor		SAD80D1-A	SAD100D1-A
	Outdoor		SAU80U1-A	SAU100U1-A
Power Supply		V~,Hz,P h	380-415,50,3	380-415,50,3
Capacity	Cooling	kW	22.0	28.0
	Heating	kW	24.5	31.0
Electric Data	Rated Cooling Power Input	kW	8.3	10.6
	Rated Heating Power Input	kW	7.5	9.48
	Rated Cooling Current	A	13.41	17.07
	Rated Heating Current	A	12.1	15.35
Performance	EER	W/W	2.65	2.64
	COP	W/W	3.27	3.27
Indoor Fan Fotor	Model		FP320A	FP320A
	Brand		Sinjun	Sinjun
	Output Power x Fan quantity	W	1239	1239
	Capacitor	uF	15×2	15×2
	Speed (Hi/Mi/Lo)	r/min	1150/1021/950	1150/1021/950
Indoor Coil	Number Of Row		4	4
	Tube Pitch(a)x Row Pitch(b)	mm	19.05×12.7	19.05×12.7
	Fin Spacing	mm	1.5	1.5
	Fin Material		Hydrophilic aluminum fin	
	Tube Outside Dia.and Material	mm	φ7,Inner grooved	φ7,Inner grooved
	Coil Length x Height x Width	mm	1200×369×50.8	1200×369×50.8
	Heat Exchanging Area	m ²	26.38	26.38
Indoor Unit	Indoor Air Flow (Hi/Mi/Lo)	m ³ /h	5000/4000/3600	5000/4000/3600
	Noise Level(Hi/Mi/Lo)	dB(A)	55	55
	External Static Pressure	Pa	150	150
	Net Dimension (W*H*D)	mm	1350×700×460	1350×700×460
	Packing Dimension (W*H*D)	mm	1540×810×610	1540×810×610
	Net Weight	Kg	90	91
	Gross Weight	Kg	110	111
Refrigerant Pipe	Liquid Side	mm	9.52(3/8)×2	9.52(3/8)×2
	Gas Side	mm	19.05(3/4)×2	19.05(3/4)×2
	Max. Refrigerant Pipe Length	m	50	50
	Max. Difference In Level	m	20	20

Operation Temperature Range		°C	16~32	16~32
Ambient Temperature Range(Cooling/Heating)		°C	16~49/-15~24	16~49/-15~24
Application Area		m ²	28-47	56-93
Connection Wiring	Power Wiring(Indoor)	mm ²	3×1mm ²	3×1mm ²
	Power Wiring(Outdoor)	mm ²	5×6mm ²	5×6mm ²
	Signal Wiring	mm ²	AWG22	AWG22
Wireless Remote Controller			XK-02	XK-02
Qty'per 20'& 40'&40HQ(Only For Reference)		Set	10/25/26	10/25/26

Note:

- Working condition of the cooling capacity measured: Inside the room DB temperature 27 °C ,WB temperature 19 °C ;Outside of the room DB temperature 35 °C ,WB temperature 24 °C ;Working condition of the heating capacity measured:Inside the room DB temperature 20 °C ,Outside of the room DB temperature 7 °C ,WB temperature 6 °C 。
- Parameters above are all measured when the connecting pipe is 5 meters.
- Parameters above may be modified as product improvement. We keep the right to change the product specifications without prior notice, please take the parameters listed on the nameplate as criteria

3 Capacity amendment**3.1 Running range**

Cooling capacity (Btu/h)		76000	96000
Power supply		380-415V 3N~/50Hz	
Voltage		220~420V	
Outdoor ambient temperature	Cooling	-5~49 °C	
	Heating	-15~24 °C	

3.2 Amendment coefficient of cooling capacity under different indoor/outdoor DB and WB temperature

Indoor air inlet temperature °C		Outdoor air inlet DB temperature °C							
DB	WB	25	30	35	40	43	45	47	49
23	16	0.98	0.94	0.89	0.85	0.82	0.79	0.74	0.71
25	18	1.05	1	0.95	0.90	0.87	0.82	0.77	0.72
27	19	1.1	1.05	1	0.95	0.91	0.87	0.84	0.79
28	20	1.12	1.07	1.02	0.96	0.93	0.90	0.86	0.81
30	22	1.19	1.13	1.08	1.02	0.99	0.96	0.91	0.88
32	24	1.26	1.20	1.15	1.08	1.05	1.02	0.97	0.92

Actual cooling capacity calculation:

Actual cooling capacity=amendment coefficient of cooling capacity × nominal cooling capacity

——nominal cooling capacity could be found from the performance parameters list

——amendment coefficient of cooling capacity could be found from table above.

3.3 Amendment coefficient of heating capacity under different indoor/outdoor DB and WB temperature

Indoor air inlet DB temperature °C	Outdoor air inlet WB temperature °C						
	-15	-10	-5	0	6	10	15
16	0.45	0.53	0.65	0.80	1.02	1.13	-
18	0.47	0.55	0.61	0.76	1.02	1.12	-
20	0.46	0.54	0.6	0.75	1	1.11	1.25
21	0.42	0.49	0.59	0.72	0.99	1.1	1.24
22	0.41	0.49	0.58	0.71	0.97	1.09	1.23
24	0.39	0.45	0.56	0.7	0.96	1.08	1.22

Actual heating capacity calculation:

Actual heating capacity=amendment coefficient of heating capacity × nominal heating capacity

——nominal heating capacity could be found from the performance parameters list

——amendment coefficient of heating capacity could be found from table above.

3.4 Amentdment coefficients of heating and cooling capacity under different height drop

Different Cooling Capacity modified coefficients at different height:

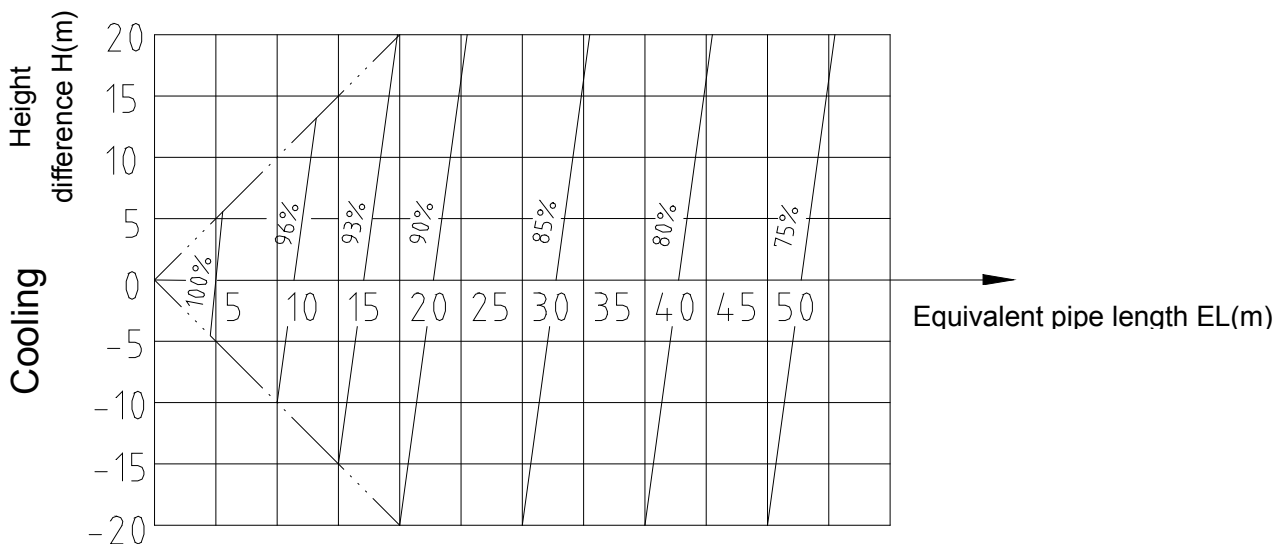

Different Heating Capacity modified coefficients at different height:

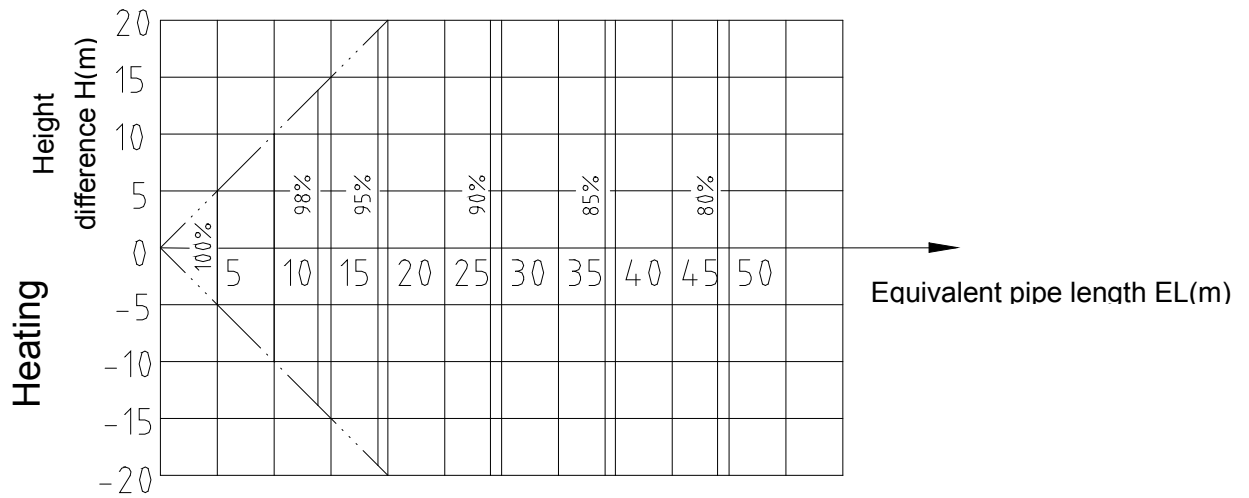

Note: H = Height of Outdoor Unit — Height of Indoor Unit

4. Dimension

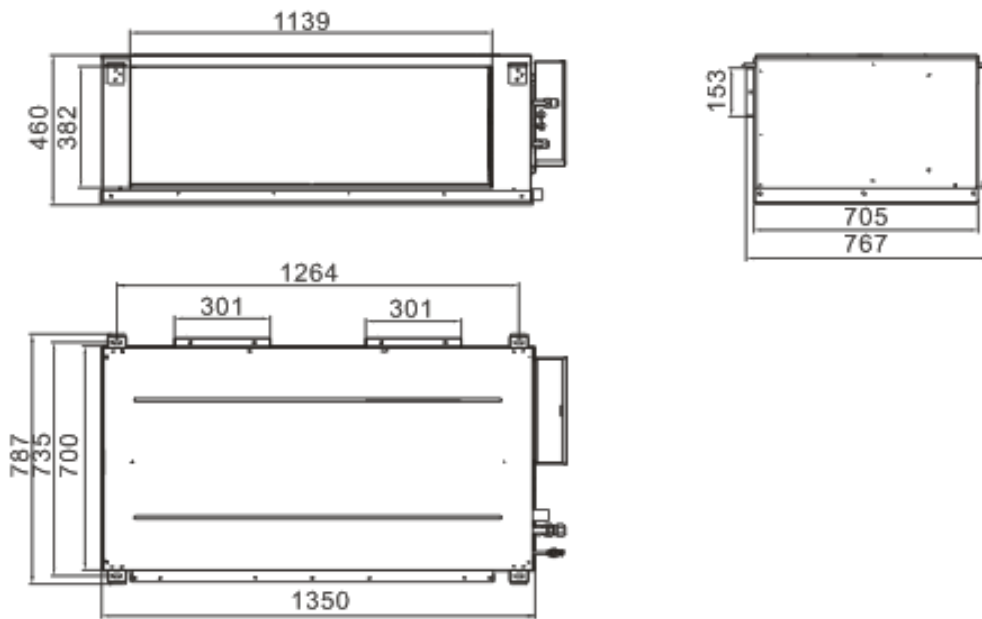

5 Electrical wiring and connection

SAD80D1-A, SAD100D1-A

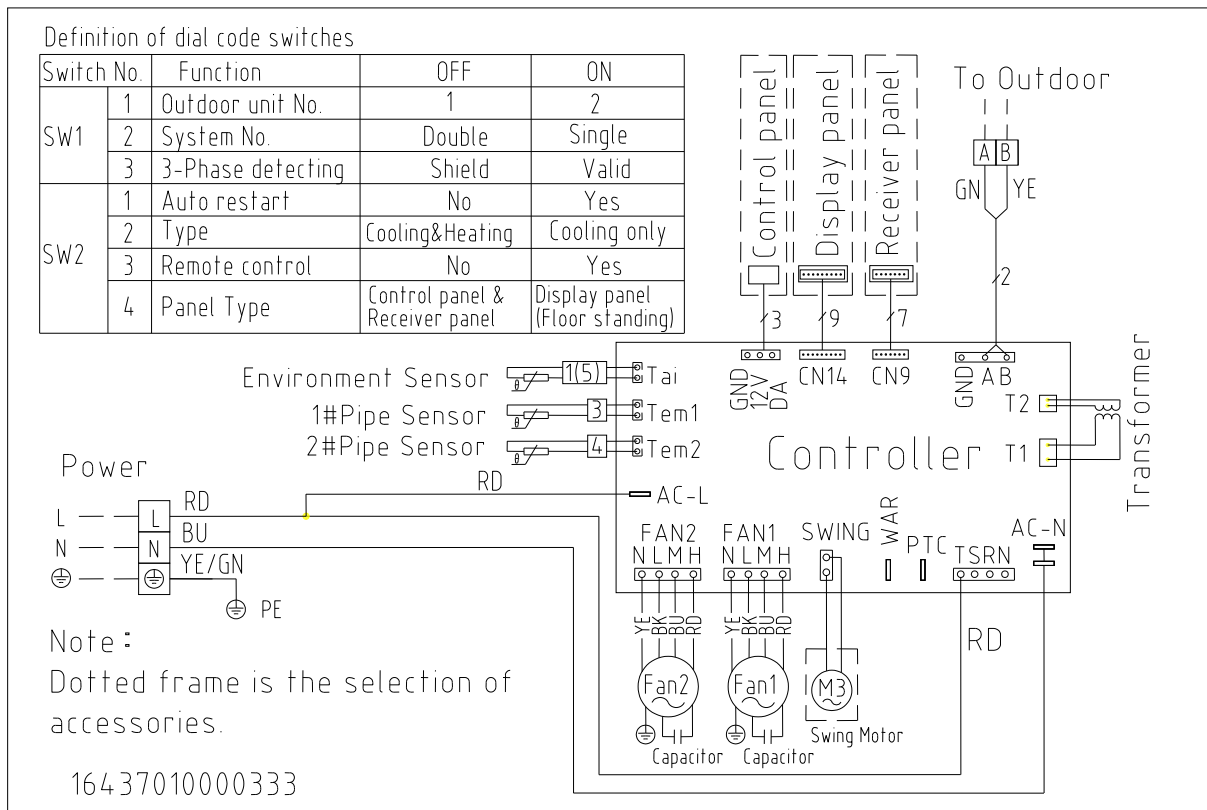

Indoor unit and outdoor unit electrical connection

SAD80D1-A, SAD100D1-A

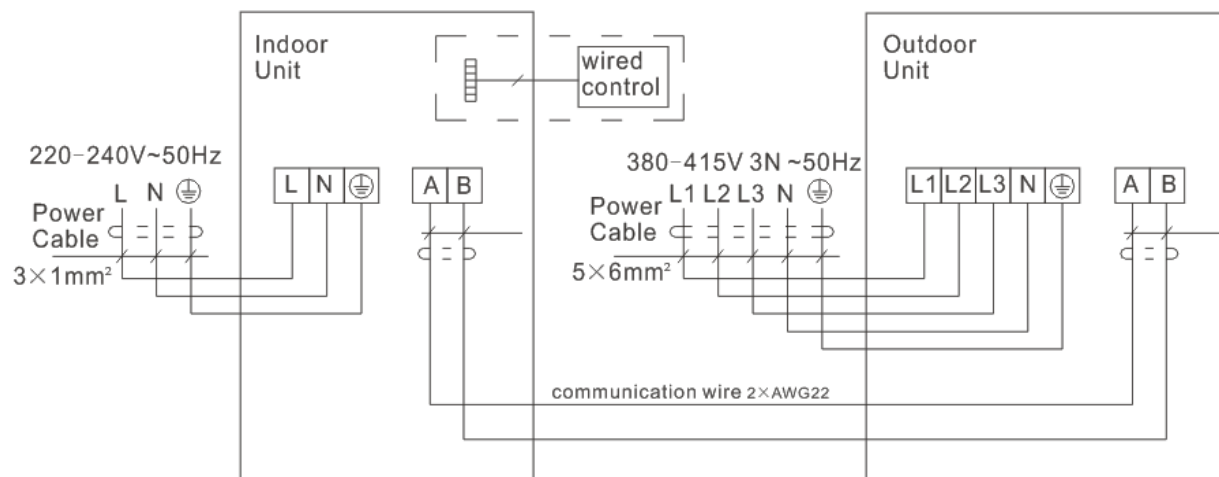

Note: Indoor machine power can also be introduced from the bonnet, which will indoor the L received the outdoor L1, L2, L3 either one,

The zero line of indoor will be connected to the corresponding zero line of outdoor, then the group line will be connected to the corresponding group line of outdoor,

6. Fan performance

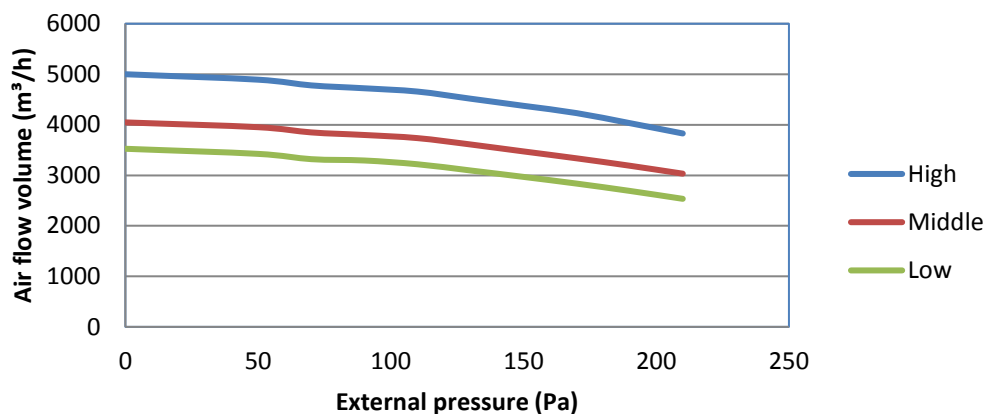

7. Installation

7.1 Preparation and equipments before installation

Please buy following spare parts from your local market before installation	Besides general implements, other implements are needed when connecting the pipe
Hung bolts M12, 4 pcs	Acetylene cylinders, oxygen cylinders (when longer pipe used it should be welded)
Drainage pipe PVC	One set pipe cut machine. (cut copper pipe)
Copper connecting pipe	Refrigerant cans, electronic balance (when longer pipe used additional gas should be charged)
Adhesive belt (big size) 5 pcs, (small size) 5 pcs	Pressure gauges, pipe clamp, welding torch, 2B silver electrode
Heat insulation material used to connect copper pipe (PE foam material, its thickness is more than 8mm)	Wrench 2 pcs, one of them is with adjustable torque wrench (42N.m,65N.m,100N.mm)
Power cable, electrical wire between indoor and outdoor unit (Must be in accordance with the wire diameter in the wiring diagram)	Nitrogen cylinder (in order to prevent oxidation when welding, using Nitrogen to replace the air)

7.2 Indoor unit installation precaution

- ◇ Hanging location should be able to support the unit's weight, there should be no increase in noise and vibration. If the hanging location needs reinforcement, it should be reinforced before installation;
- ◇ Choose the space above the ceiling that can put the indoor unit inside;
- ◇ The location should be easy for drainage;
- ◇ The unit should not be installed in the heat source, steam source, oil mist places (such as machine room, kitchen, laundry room, mechanical workshop, etc.) in order to avoid performance degradation, electric shock, plastic parts corrosion which lead to unit broken;
- ◇ Choose the location at least 1 meter away from TV and radio, in order to avoid interference to them
- ◇ There is no obstacles getting in the way of air circulation, cold air can evenly spread to all corners of the room;

- ◇ In order to facilitate maintenance and repair, there should be certain distance between indoor unit and obstacles;
- ◇ Refrigerant R410A is used for this unit, which is non-flammable and non-toxic gas. As the proportion of refrigerant is bigger than air, so if it leaks the gas will be filled on the ground. Therefore, if the units mounted on a closed room there must be good ventilation to prevent suffocation. In case of leakage of refrigerant, units should immediately stop running, and contact with maintenance personnel in time. There must be no fire at the site, because the refrigerant will turn to harmful gas when get to the fire.

7.3 The distance between indoor unit and obstacle

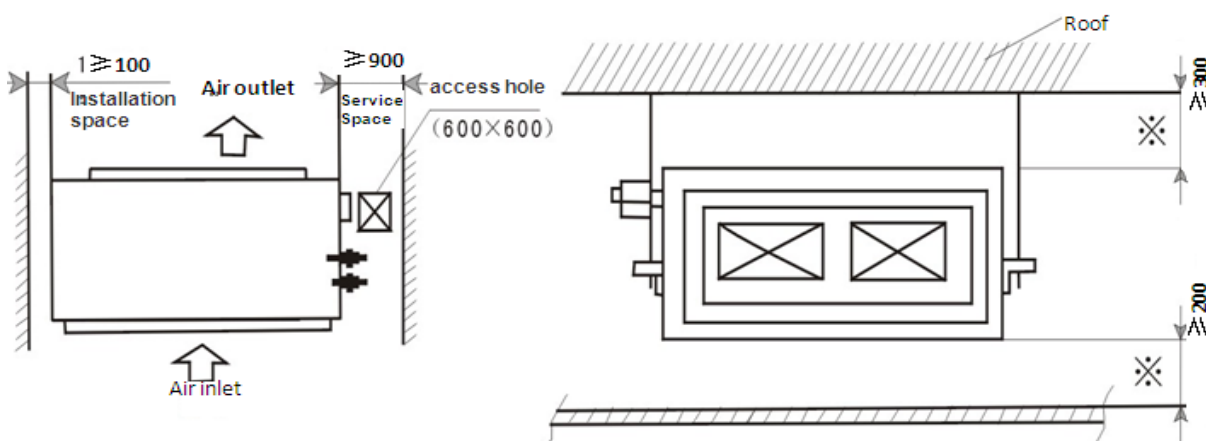

7.4. Indoor unit suspension

- ◇ Select the suspension foundation

The suspension foundation is a structure of either wooden frame or reinforced concrete. It must be firm and reliable to bear at least 4 times weight of itself and capable of bearing vibration for long periods;

- ◇ Fixing of suspension foundation

Fix the suspension bolts either as shown in the picture or by a steel or wooden bracket;

- ◇ Adjust the relative positions of the suspension hooks to ensure the indoor unit is level in all directions. Use a spirit level to ensure this, otherwise water leakage, air leakage etc. will be resulted;

- ◇ Tighten the nuts and ensure that the hooks are tightly connected to the nuts and shims, and there is no phenomenon of virtual hanging;

- ◇ After the unit is installed ensure it is secure and does not shake or sway.

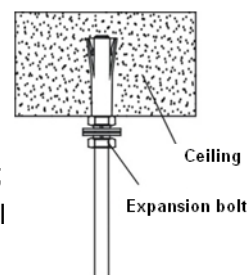

7.5 Duct pipeline installation

- ◇ Using canvas to connect between indoor unit and duct pipeline, in order to save unnecessary vibration, as to the detail connection method please refer to the following picture.

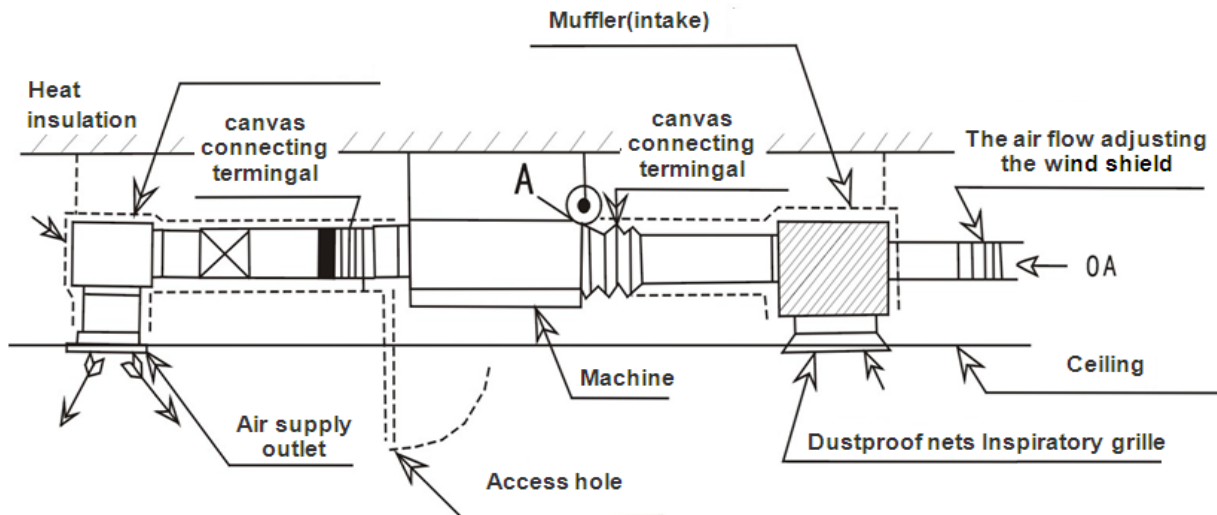

7.6 Drainage pipe installation

◇ Drainage pipes must be wrapped with heat insulation materials, otherwise it will cause frost or droplets, see picture as follows:

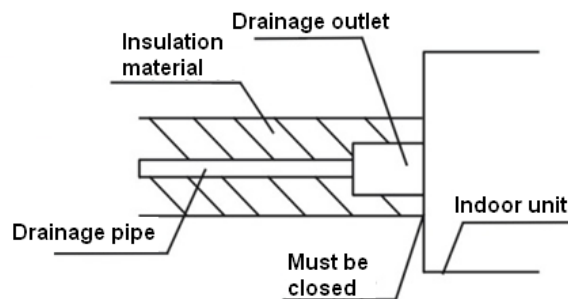

Heat insulation material: rubber insulation pipe with the thickness of more than 8mm

◇ Drainage pipe must have a downward gradient (1/50--1/100). If the drain pipe is installed ups and downs, it will cause water backflow or leakage etc.

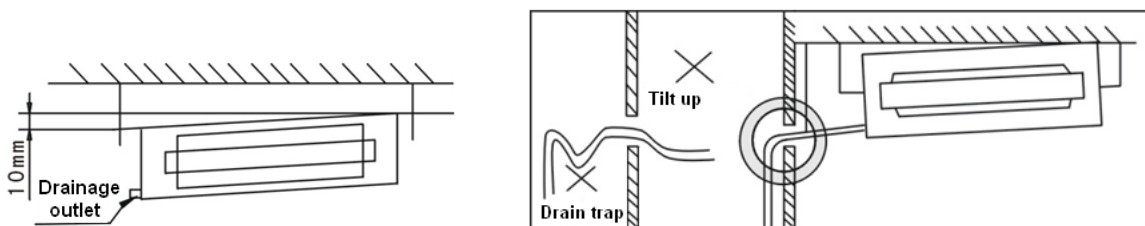

◇ When finish installation please carry out the drainage test to ensure that the water flow through the pipeline fluently, and carefully observe the junction to ensure that there is no water leakage at the junction. If the unit is installed in the newly built house, strongly recommend that this test taken before the ceiling installation. Even it is the heating only unit, this test is unavoidable.

7.7 Remote controller receiver installation.

◇ Installation site: recommend that the receiver is mounted with the distance of 30~50 cm to the indoor unit air outlet (on your choice as well), while must ensure that the receiver can get the signal that the remote controller sends, please refer to the following installation picture:

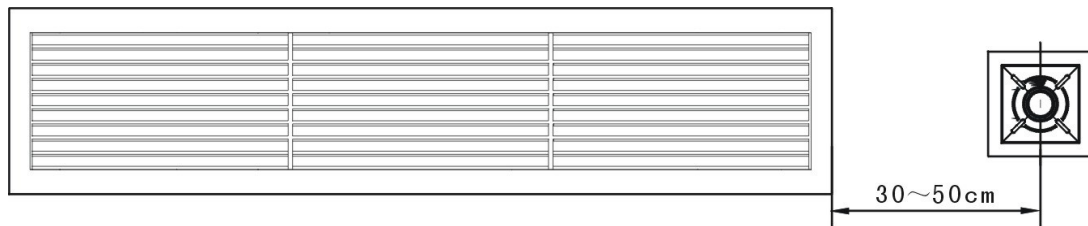

NOTES:

The remote control signal effectively work for straight line from 8 meters, when the battery after the power consumption, effective work will shorten the distance

- ◇ Mounting hole set up: please use certain instrument to dig a square hole with 88x88mm on the ceiling
- ◇ Remote controller receiver installation.

Hold the two sides (with clip sides) of the receiver, set the spring clip in the vertical way then put it into the mounting hole, if the two sides of the receiver is in the same level with the ceiling the installation is finished.

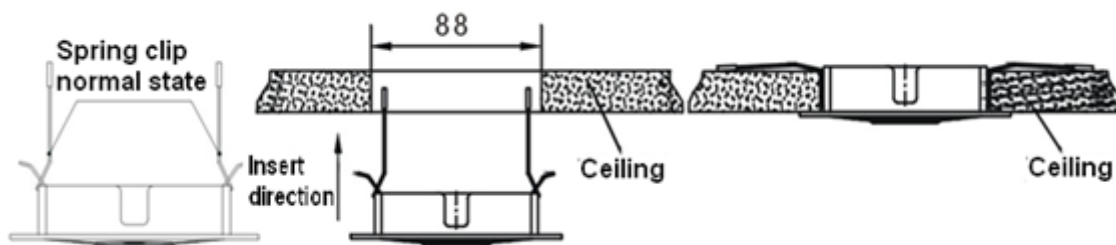

- ◇ Signal line connection: connect the wire of remote controller receiver to the CN-DISP terminal board on PCB of indoor unit wire box then fix it.

Part 2 Outdoor unit

1. Specification	17
2.Capacity Amendment	37
3. Dimension	22
4.System principle diagram	22
5.Electrical wiring and connection.....	23
6. Installation.....	24

1. Specification

Model			SAU80U1-A	SAU100U1-A
Power Supply		V~,Hz,P h	380-415,50,3	380-415,50,3
Max. Input Consumption		W	11320	11320
Max. Current		A	19.59	19.59
Capacity	Cooling	kW	22.0	28.0
	Heating	kW	24.5	31.0
Compressor	Model		QXAS-H49SN330	QXAS-H49SN330
	Type		Rotary	Rotary
	Brand		Landa	Landa
	Capacity	W	12600	12650
	Input	W	4130	4130
	Rated Current(RLA)	A	7.5	7.5
	Locked Rotor Amp(LRA)	A	59	59
	Thermal Protection temp.	°C	115	115
	Capacitor	uF	/	/
	Refrigerant Oil	ml	1500	1500
OutdoorFan Motor	Model		CW160A+CW160B	CW160A+CW160B
	code		16430001000577	16430001000578
	Brand		Sinjun	Sinjun
	Output Power x Fan quantity	W	160×2	160×2
	Capacitor	uF	8	8
	Speed	r/min	860/690/550	860/690/550
Coil	Number Of Row		2	2
	Tube Pitch(a)x Row Pitch(b)	mm	22×19.05	22×19.05
	Fin Pitch	mm	1.4	1.4
	Fin Material		Hydrophilic aluminum fin	
	Tube Outside Dia.and Material	mm	φ7	φ7
	Coil Length x Height x Width	mm	1112×1496×38.1	1112×1496×38.1
	Heat Exchanging Area	m ²	83.2	83.2
Air Flow Volume		CFM	10200×2	10200×2
			m ³ /h	6000×2
Noise Level		dB(A)	58	58
Dimension(W×D× H)	Net	mm	1120×400×1510	1120×400×1510
	Packing	mm	1270×545×1710	1270×545×1710
Weight	Net	kg	175	176

Weight	Gross	kg	190	191
--------	-------	----	-----	-----

Refrigerant	Type		R410A	R410A
Type/Quantity	Charged Volume	g	2*2700	2*2700
Design Pressure		MPa	4.4	4.4
Refrigerant Piping	Liquid Side	mm	9.52(3/8)×2	9.52(3/8)×2
	Gas Side	mm	19.05(3/4)×2	19.05(3/4)×2
	Max. Length	m	50	50
	Max. Height	m	20	20
Operation Temperature Range		°C	16~32	16~32
Ambient Temperature Range(Cooling/Heating)		°C	16~49/-15~24	16~49/-15~24
Application Area		m ²	150-180	150-180
Connection Wiring	Power Wiring(Indoor)	mm ²	3×1mm ²	3×1mm ²
	Power Wiring(Outdoor)	mm ²	5×6mm ²	5×6mm ²
	Signal Wiring	mm ²	2×AWG22	2×AWG22

Notes:

1. Nominal cooling capacities are based on the following conditions: Return air temp.: 27°CDB, 19°CWB, and outdoor temp.: 35°CDB, 24°CWB;
2. Nominal heating capacities are based on the following conditions: Return air temp.: 20°CDB, and outdoor temp.: 7°CDB, 6°CWB;
3. Parameters above are all measured when the connecting pipe is 5 meters.

Model			SAU80D1-A	SAU100D1-A
Power Supply		V~,Hz,Ph	380-415,50,3	380-415,50,3
Max. Input Consumption		W	11570	11570
Max. Current		A	20.1	20.1
Capacity	Cooling	kW	22.0	28.0
	Heating	kW	24.5	31
Compressor	Model		QXAS-H49SN330	QXAS-H49SN330
	Type		Rotary	Rotary
	Brand		Landa	Landa
	Capacity	W	12650	12650
	Input	W	4130	4130
	Rated Current(RLA)	A	7.2	7.2
	Locked Rotor Amp(LRA)	A	69	69
	Thermal Protection temp.		165	165
	Capacitor	uF	/	/
Refrigerant Oil	ml	1600	1600	

OutdoorFan Motor	Model		CW160A+CW160B	CW160A+CW160B
	Brand		Sinjun	Sinjun
	Output Power x Fan quantity	W	160×2	160×2
	Capacitor	uF	8	8
	Speed	r/min	860/690/550	860/690/550
Coil	Number Of Row		2	2
	Tube Pitch(a)x Row Pitch(b)	mm	22×19.05	22×19.05
	Fin Pitch	mm	1.4	1.4
	Fin Material		Hydrophilic aluminum fin	
	Tube Outside Dia.and Material	mm	φ7	φ7
	Coil Length x Height x Width	mm	1112×1496×38.1	1112×1496×38.1
	Heat Exchanging Area	m ²	83.2	83.2
Air Flow Volume		CFM	10200×2	10200×2
			m ³ /h	6000×2
Noise Level		dB(A)	58	58
Dimension(W× D×H)	Net	mm	1120×400×1510	1120×400×1510
	Packing	mm	1270×545×1710	1270×545×1710
Weight	Net	kg	175	176
	Gross	kg	190	191
Refrigerant Type/Quantity	Type		R410A	R410A
	Charged Volume	g	2*2450	2*2450
Design Pressure		MPa	4.4	4.4
Refrigerant Piping	Liquid Side	mm	9.52(3/8)×2	9.52(3/8)×2
	Gas Side	mm	19.05(3/4)×2	19.05(3/4)×2
	Max. Length	m	50	50
	Max. Height	m	20	20
Operation Temperature Range		°C	16~32	16~32
Ambient Temperature Range(Cooling/Heating)		°C	16~49/-15~24	16~49/-15~24
Application Area		m ²	150-180	150-180
Connection Wiring	Power Wiring(Indoor)	mm ²	3×1mm ²	3×1mm ²
	Power Wiring(Outdoor)	mm ²	5×6mm ²	5×6mm ²
	Signal Wiring	mm ²	2×AWG22	2×AWG22

Notes:

1. Nominal cooling capacities are based on the following conditions: Return air temp.: 27°CDB, 19°CWB, and outdoor temp.: 35°CDB, 24°CWB;
2. Nominal heating capacities are based on the following conditions: Return air temp.: 20°CDB, and outdoor temp.: 7°CDB, 6°CWB;
3. Parameters above are all measured when the connecting pipe is 5 meters.

2 Capacity Amendment

2.1 Running range

Cooling capacity (кВт)		22.0	28.0
Power supply		380-415V 3N~/50Hz	
Voltage		320~420V	
Ambien temperature	Cooling	16~49℃	
	Heating	-15~24℃	

2.2 Amendment coefficient of cooling capacity under different indoor/outdoor DB and WB temperature

Indoor air inlet temperature℃		Outdoor air inlet DB temperature℃							
DB	WB	25	30	35	40	43	45	47	49
23	16	0.98	0.94	0.89	0.85	0.82	0.79	0.74	0.71
25	18	1.05	1	0.95	0.90	0.87	0.82	0.77	0.72
27	19	1.1	1.05	1	0.95	0.91	0.87	0.84	0.79
28	20	1.12	1.07	1.02	0.96	0.93	0.90	0.86	0.81
30	22	1.19	1.13	1.08	1.02	0.99	0.96	0.91	0.88
32	24	1.26	1.20	1.15	1.08	1.05	1.02	0.97	0.92

Actual cooling capacity calculation:

Actual cooling capacity=amendment coefficient of cooling capacity × nominal cooling capacity

——nominal cooling capacity could be found from the performance parameters list

——amendment coefficient of cooling capacity could be found from table above.

2.3 Amendment coefficient of heating capacity under different indoor/outdoor DB and WB temperature

Indoor air inlet DB temperature℃	Outdoor air inlet WB temperature℃						
	-15	-10	-5	0	6	10	15
16	0.45	0.53	0.65	0.80	1.02	1.13	-
18	0.47	0.55	0.61	0.76	1.02	1.12	-
20	0.46	0.54	0.6	0.75	1	1.11	1.25
21	0.42	0.49	0.59	0.72	0.99	1.1	1.24
22	0.41	0.49	0.58	0.71	0.97	1.09	1.23
24	0.39	0.45	0.56	0.7	0.96	1.08	1.22

Actual heating capacity calculation:

Actual heating capacity=amendment coefficient of heating capacity × nominal heating capacity

——nominal heating capacity could be found from the performance parameters list

——amendment coefficient of heating capacity could be found from table above.

2.4 Amendment coefficients of heating and cooling capacity under different height drop

Different Cooling Capacity modified coefficients at different height:

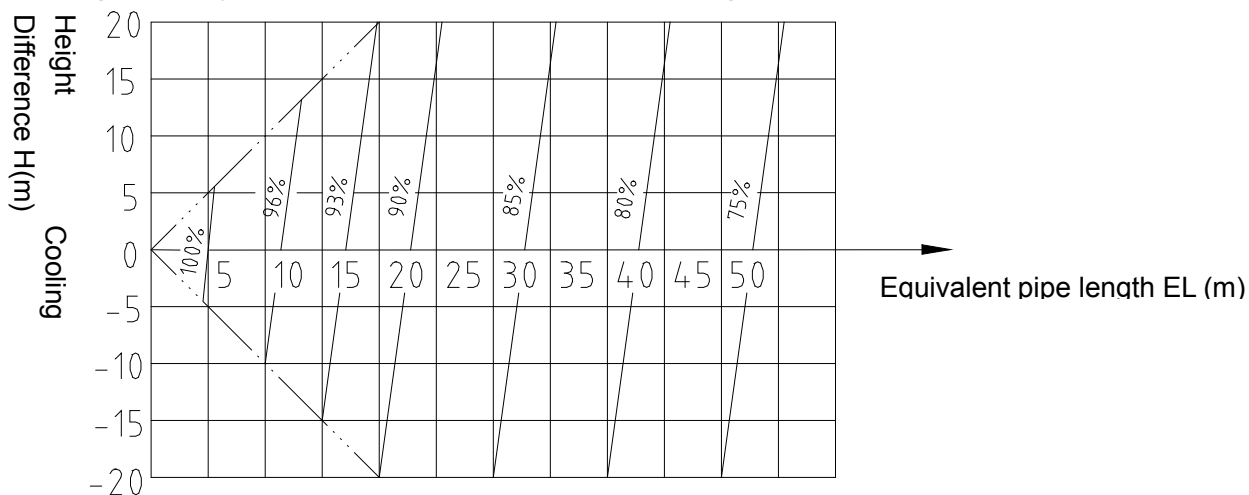

Note: H = Height of Outdoor Unit — Height of Indoor Unit

2.5 Different Heating Capacity modified coefficients at different height:

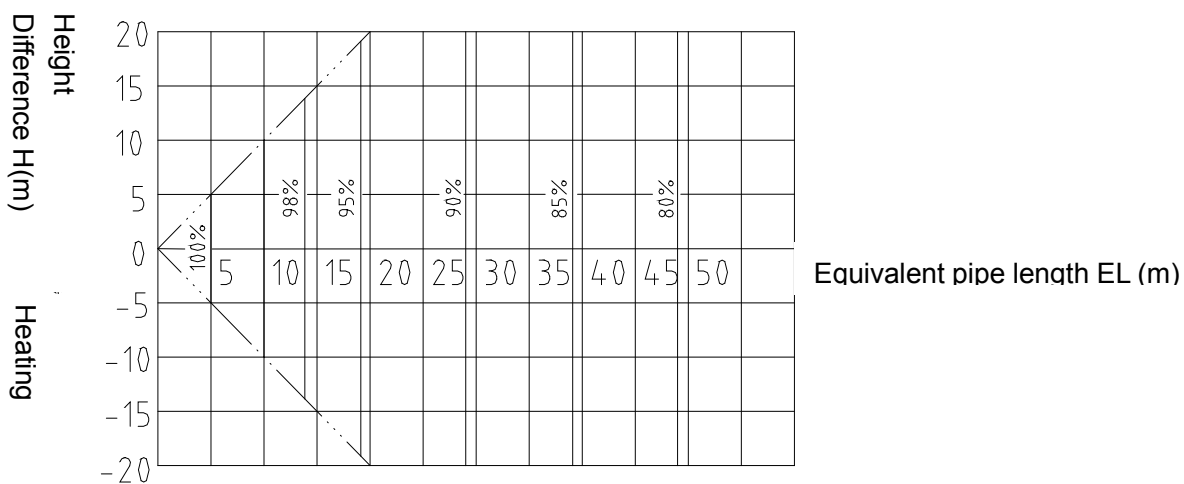

Note: H = Height of Outdoor Unit — Height of Indoor Unit

3. Dimension

SAU80D1-A, SAU100D1-A

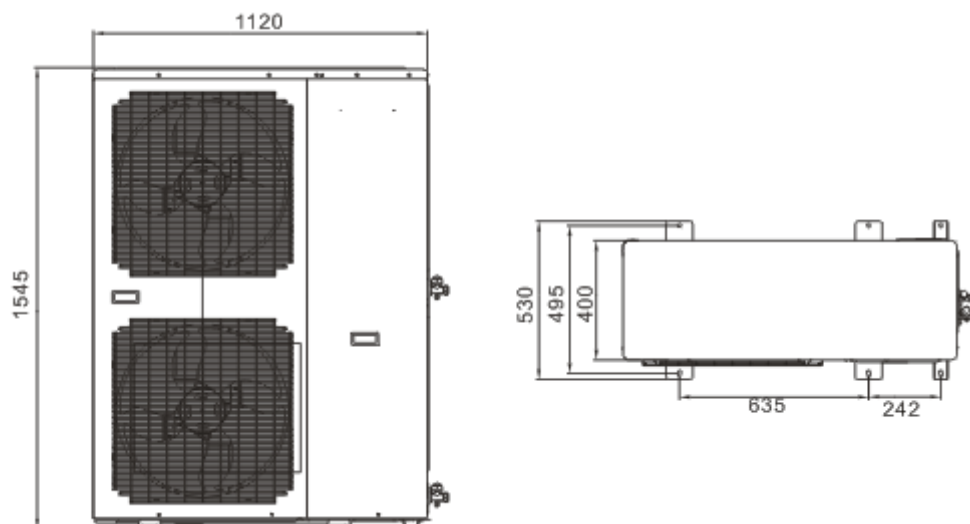

4. System principle diagram

Cooling cycle:

the Compressor inhales the low-temperature and low-pressure refrigerant vapor from the evaporator, and vapor be turned into high-temperature and high-pressure gas then enters into condenser, the high-temperature and high-pressure refrigerant gas and outdoor air make heat exchange in the condenser, the compressed vapor is then cooled by heat exchange with the outside air, so that the vapor condenses to be a high-temperature and high-pressure fluid, and then through capillary throttling to cooled, low pressure, then the liquid enters into the evaporator and two-phase of gas and liquid refrigerant in the evaporator completely evaporate, thereby cooling the indoor air; from evaporator the vapor is inhaled into compressor again, so it runs continuously cycle to cycle, cooled air is continuous supplied to the air-conditioned area though Duct by fan motor.

Heating cycle:

It is the contrary cycle of cooling cycle, at this moment the 4-way valve changes direction, and make refrigerant flow to direction changer, that is, the vapor discharged from the compressor enters into the indoor heat exchanger to condense, the condensation of refrigerant after the capillary expenditure, evaporates in the outdoor heat exchanger, and then inhaled by the compressor after evaporation, so it runs continuously periodically , the heated air is continuous supplied to the air-conditioned area though duct by fan motor.

6. Installation

Preparation and equipments before installation

Please buy following spare parts from your local market before installation	Besides general implements, other implements are needed when connecting the pipe
Hung bolts M12, 4 pcs	Acetylene cylinders, oxygen cylinders (when longer pipe used it should be welded)
Drainage pipe PVC	One set pipe cut machine. (cut copper pipe)
Copper connecting pipe	Refrigerant cans, electronic balance (when longer pipe used additional gas should be charged)
Adhesive belt (big size) 5 pcs, (small size) 5 pcs	Pressure gauges, pipe clamp, welding torch, 2B silver electrode
Heat insulation material used to connect copper pipe (PE foam material, its thickness is more than 8mm)	Wrench 2 pcs, one of them is with adjustable torque wrench (42N.m,65N.m,100N.mm)
Power cable, electrical wire between indoor and outdoor unit(Must be in accordance with the wire diameter in the wiring diagram)	Nitrogen cylinder (in order to prevent oxidation when welding, using Nitrogen to replace the air)

Select installation position of outdoor unit

- ◇ The site shall be strong enough to bear its weight, prevent noise and vibration.
- ◇ The site shall be ensured to avoid direct sunshine, if necessary set a Havelock above the outdoor unit.
- ◇ The site shall be easy to drainage the rain water and the frost water.
- ◇ The site shall be ensured that the outdoor unit will not be covered by snow LDring the winter season.
- ◇ The site shall be ensured that the outlet is not facing the strong wind.
- ◇ The site shall be ensured that outlet air and operation noise will not affect the neighbors' daily life.
- ◇ The site shall be ensured that the outdoor unit will not be affected by the garbage and oil mist.

Warning :

If outdoor unit working under such environment which contains oil (including machine oil) salt(marine areas), sulfide gas (hot springs and oil refinery areas), those substance may lead to the failure work of the outdoor unit.

Maintenance and ventilation space

- ◇ The site shall be easy for ventilation then the outdoor unit can inhale and discharge air easily. What's more please reserve enough space for maintenance.

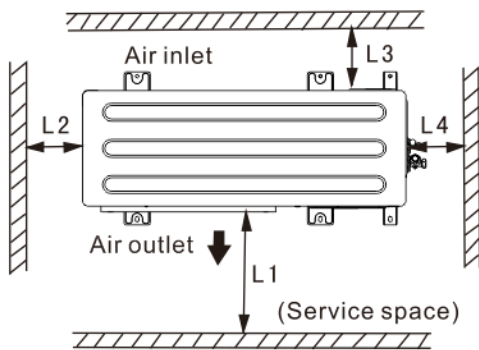

From	Instance	Distance(mm)
	L1	≥2000
	L2	≥300
	L3	≥300
	L4	≥400

Unit: mm

Outdoor unit installation

- ◇ Use size M10 bolt and nut to fasten the outdoor unit tightly on the bracket, keep it in the horizontal level. The suitable length for bolt shall 20mm over the base level, in order to minimize vibration please do set a rubber shock absorber.
- ◇ If the outdoor unit is mounted on the wall or on the rooftop, in order to prevent earthquake and strong wind please fasten it as tightly as possible.
- ◇ Set a drainage channel to ensure the condensing water can drain out smoothly.
- ◇ To avoid that only four angles metal sheet to support the outdoor unit.

7.2 Connection piping installation

Piping installation precaution

Please choose the phosphorus deoxidation seamless copper pipe as the piping.

- ◇ If use the lengthen piping needs welding:
 - Please welding before fasten the nut, when welding using nitrogen gas to replace the air in the pipe in order to prevent oxidation.
- ◇ If there are many points to be welded when installing the lengthen piping, please set a filter in the pipe(buy from local market)
- ◇ Please use nitrogen gas or air to remove the dust and water in the pipe,
- ◇ Please lay out the piping according to the tend towards of the piping, but it is not allowed more than 3 times curved at the same point of the pipe(if do like this the pipe will become rigid)
- ◇ Pipe bending machine is used during the process of bending the pipe, the curvature shall not be too small or it will affect the refrigerant flow.

Piping specification selection

As to the detail selection please take reference to the cooling capacity adjust index figure during different installation situations.

Piping diameter	Tighten torque	Expanding size	Expanding shape	Paint the frozen oil
1/4in(φ6.35mm)	15-19(N·m)	8.3-8.7mm		
3/8in(φ9.52mm)	35-40(N·m)	12.0-12.4mm		
1/2in(φ12.7mm)	50-60(N·m)	15.4-15.8mm		
5/8in(φ15.88mm)	62-76(N·m)	18.6-19.0mm		
3/4in(φ19.05mm)	70-75(N·m)	22.9-23.3mm		

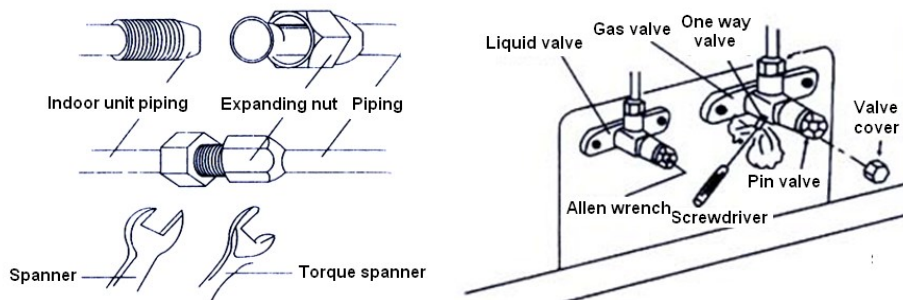

Piping connection

- ◇ Using expanding machine to expand accessories, the size of horn shown in the above figure:
- ◇ Paint a thin layer of frozen oil at both inside and outside part of the expanding.
- ◇ Make the expanding right to the screw thread shape connection of the indoor unit, using hands to tighten the nut then using a wrench to tighten the nut again, the tighten torque as follows figure.
- ◇ Take out the cover of the indoor unit gas valve and liquid valve, make the expanding right to the stop valve of outdoor unit, using hands to tighten the nut then using a wrench to tighten the nut again, the tighten torque as follows figure.

Equivalent pipe length conversion

Equivalent pipe length means converting pipe elbow to straight pipe length after considerate the pressure loss.

Elbow and Oil loop conversion tablet

Pipe Dia.(mm)	Type	Bend	Oil Loop
6.35		0.10	0.7
9.52		0.18	1.3
12.70		0.20	1.5
15.88		0.25	2.0
19.05		0.35	2.4
22.02		0.40	3.0

Equivalent pipe length $L = \text{Actual Pipe length } L + \text{Bend Qty} \times \text{Equivalent pipe bend length} + \text{Oil Loop Qty} \times \text{Equivalent Oil Loop length}$

Specification of connection pipe for indoor unit and outdoor unit

Cooling Capacity (kBT)		22.0	28.0
Connection Pipe (mm)	Liquid Pipe	Φ9.52	
	Gas Pipe	Φ19.05	
Max. Length(m)	Liquid Pipe Dia.	Φ9.52	
	Gas Pipe Dia.	Φ19.05	
	Max. Length	50	
Max. Height (m)		20	
Max. Bend Qty		10	
Extra R410a per meter when the pipe length is more than 5 meter (kg)		0.09	

Caution:

1. The standard Pipe length is 5m, if the pipe length is less than this then no additional charging is necessary. If the pipe length is more than this then you should charge more refrigerant into the system according to the above Charging Data
2. The thickness of the pipe is 0.5-1.0, bearing pressure is 3.040MPa;
3. If the connection pipe is too long, the cooling capacity and stability would be decreased. And the more bend quantity, the resistance in the piping system would be bigger, then the cooling and heating capacity would be decreased even lead to compressor broken. We suggest you to use the shortest connection pipe according to the pipe length parameter in this manual.

Emptying or vacuum

Before charging the refrigerant to the system, to ensure that there is no impurities, water or non-condensable gas. So, emptying and vacuum operation should be carried out.

◇ Vacuum: when process this operation please be sure that the connection pipe is tightened up.

1. Screw off the cover of maintenance valve connection, connect the pressure gauge to the connection of maintenance valve
2. Connect the vacuum pump to the pressure gauge, turn on the vacuum pump and pressure gauge to process the vacuum operation toward the indoor unit and piping, while to ensure that the absolute pressure is no less than 50Pa after this operation.
3. Turn off the pressure gauge and vacuum pump to keep the pressure in the same level in 20 minutes.

◇ Emptying: when process this operation, please disconnect the high pressure valve with liquid valve.

1. Connect the gas valve of the stop valve to the thimble side of the rubber hoses, the other side of rubber hoses should be connected to the refrigerant tank.
2. Open the refrigerant tank valve, using the refrigerant inside the tank with high speed to empty the air in the indoor unit and the connection piping. When the outlet air becomes mist (it feels cold by touching it), then the air is emptied.
3. When ensure that the air is emptied, connect and tighten the high pressure valve of outdoor unit stop valve and liquid side connection pipe, keep this state more than 10 seconds.
4. Use soapy what to test each connection junctions (including lengthen piping welding junction)
5. Confirmed that there is no leakage, turn off the valve of refrigerant tank, take down the rubber hose as well.

◇ Turn on the high-low pressure valve of the outdoor unit.

After vacuum and emptying, screw back the cover of the maintenance valve of outdoor unit low pressure valve, screw off the high-low pressure valve of the outdoor unit (note: shall totally turned off). Connect the refrigerant to the system.

Heat insulation package of piping

◇ Use heat insulation material with good insulation performanCF to wrap the pipe.

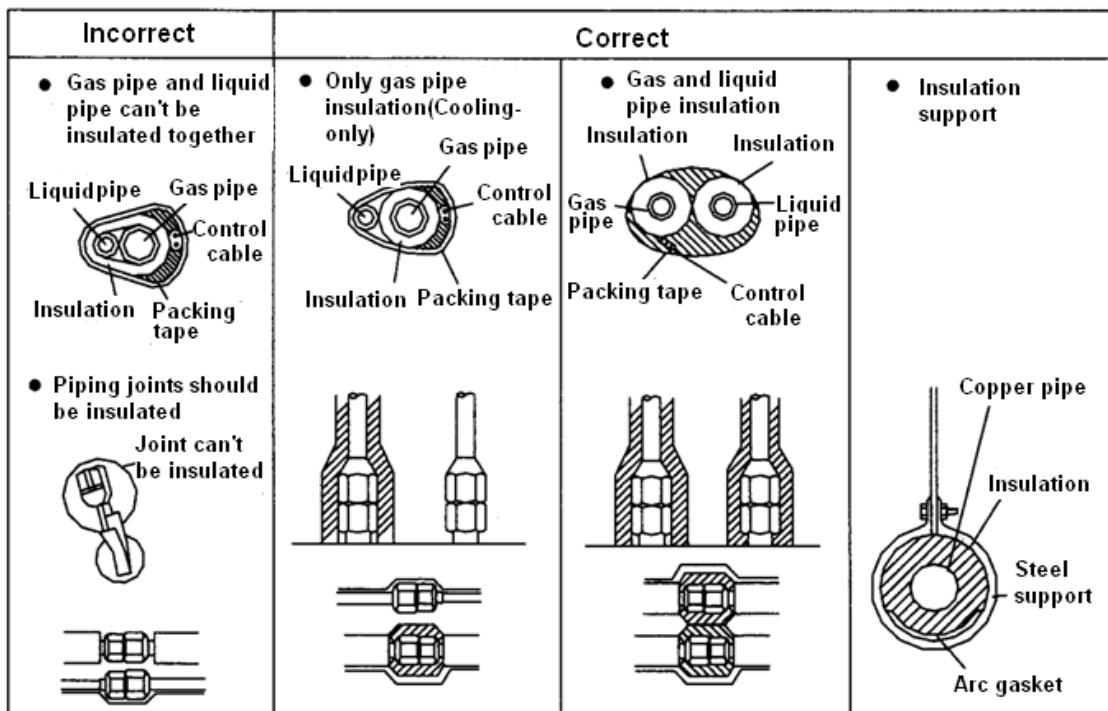

Notes

Drainage pipe and connection piping should be wrapped by heat insulation material respectively or there will be dew or leakage

During the high temperature working environment, our air conditioner is proved my dew conditioner experiment. But if it keeps on working during the high humidity (the dew temperature is more than 23°C) environment which may lead to water leakage, in such condition please use following additional insulation material:

- ◇ Glass fiber insulation material with the thickness between 10~20mm can be used.
- ◇ The part of indoor unit which get in touch with the back side of ceiling should pasted with insulation material.
- ◇ Besides the previously more than 8mm thick insulation material, connection piping (both gas pipe and liquid pipe), drainage pipe should be wrapped by additional 10~30 mm thick insulation material.

To seal the hole on the wall.

- ◇ To prevent rainwater or other foreign bodies from entering the room and air-conditioner after installing the tubing and drain pipe, the gap between wall hole and tubing, drain pipe and electric wire should be sealed with mastic, sealant rubber or putty, or poor performance or leakage will result
- ◇ If the outdoor unit is higher than indoor unit, tubing should be bent to ensure that the lowest point of the tubing is lower than the wall hole to prevent rainwater entering the room or air-conditioner along the piping system.

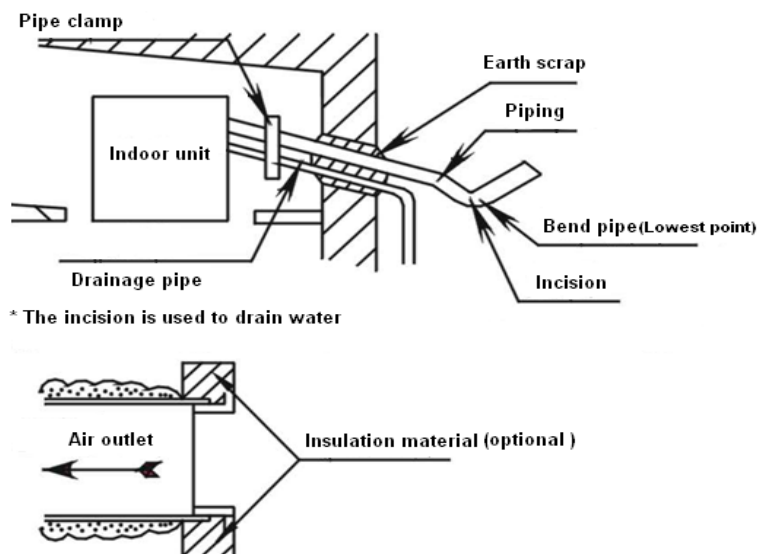

Additional refrigerant charge

When pipe length exceeds 5m, please add refrigerant according to the table below:

Connection piping	Piping size)		Additional refrigerant charge amount (kg/m)
	Gas pipe	Liquid pipe	
Piping between indoor and outdoor unit	φ9.52×0.75mm	φ6.35×0.75mm	0.02
	φ12.7×1mm	φ6.35×0.75mm	0.02
	φ15.88×1mm	φ9.52×0.75mm	0.05
	φ19.05×1mm	φ9.52×0.75mm	0.07
	φ22.02×1mm	φ12.7×1mm	0.09

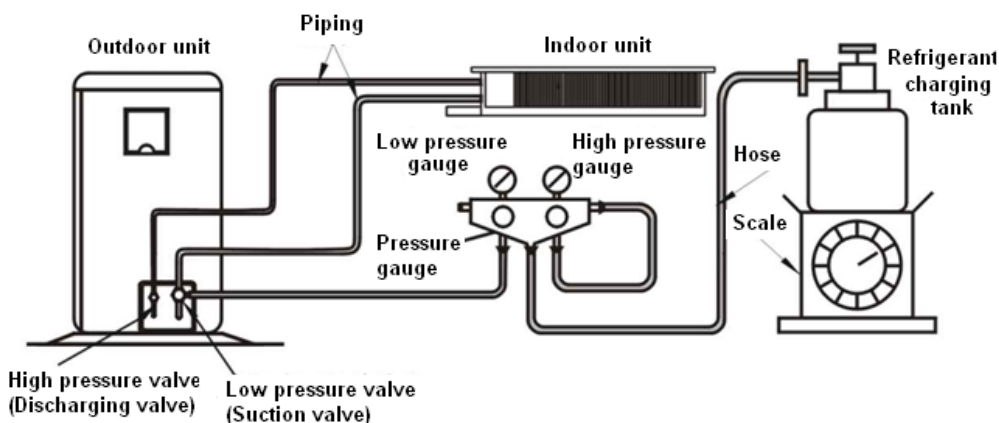

Others

Users to install the air conditioner at site shall ensure that the oil can return to the unit smoothly.

- ◇ Horizontal pipes should incline toward the outdoor unit using a 20:1 slope
- ◇ If there is a height difference between the indoor and outdoor unit, oil loops should be installed in the inter connecting gas (large) pipe;

When the vertical pipe height difference is less than 5 meters, an oil loop should be installed at the bottom of

the gas (large) pipe;

When the vertical pipe height difference is more than 5 meters, then for every 5 meters an oil loop must be installed at the bottom of the gas (large) pipe, and a short loop (liquid ring) should be installed at the exit of the indoor unit liquid (small) pipe;

When the connecting gas pipe vertical height difference is less than 5 meters but the constant rise distance is too long, an oil loop should be installed in the gas (large) pipe every 10 meters.

◇When the outdoor and indoor units are at the same elevation, the oil deposit bend and liquid ring do not need to be installed, if the horizontal connecting pipe length is less than 10 meters.

When the horizontal connecting pipe length is more than 10 metres, install an oil loop in the gas (large) pipe every 10 metres.

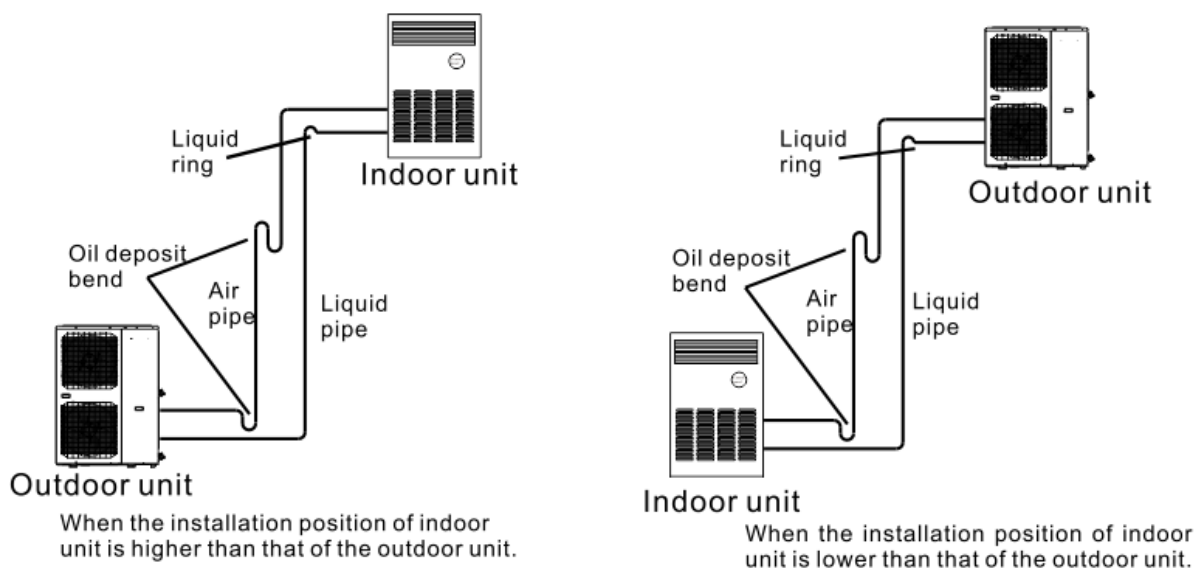

Note:

This chart is for explanation purposes. An actual installation will differ from this according to the site conditions. When making an oil trap the radius of the bend should be between 1.5 and 2 times the pipe diameter.

7.3. Electrical connection

7.3.1 Electrical connection precaution

Warning	Installation of electric items must be carried out by qualified, professional technicians. An isolated circuitry should be fixed with whole-pole disconnection devices, which is with at least 3mm gap of touch point. . Power supply and indoor to outdoor connection should use special cable. Providing the necessity of installation or replacement, the professional technician of service store appointed by manufacturer must be required, while self-operation by users is prohibited.
	In case of any electric shock accident, the creepage protection devices /power supply on-off and breaker must be required with power supply.
	The specification of fuse for single phase control board is F5AL 250V, while for 3 phase control board, both indoor and outdoor unit, it is F3.15AL 250V .
	Machine must be earthed surely. If not, it'll be probably caused creepage.

	Equivalent 227IEC53(RVV) type of power cord of GB5023 or the excelled must be required. The cords should be fixed properly against broken, while ends/joints of cords is under outside force. Improper connection or fixation will cause disaster like fire....etc. Equivalent 245IEC57(YZW) type of power cord of GB5023 or the excelled must be used as connection line of indoor and outdoor.
Notice	The earth line is neither allowed to connect to gas pipe, water pipe or circuitry of telephone or lighting rod, nor to the earth line of other devices.
Others	Please fix power supply cord and connection wires of indoor and outdoor, in accordance with circuit diagram Fix the cords into terminal boards properly and safely with cable fixation tools to avoid any danger caused by the power cord under outside forces. After fixation, use bind tape (affixed) to bind wires avoiding any collision with other components like compressor, copper pipes...etc

7.3.2 Electrical connection

Wiring diagram of indoor & outdoor, refer to the section of part 1

Recommendation of power supply cord

Power supply 380V-415V~,3N,50Hz

Cooling capacity (kBT)	Model No.	Power supply spec.	Power supply cord of indoor unit	Power supply cord of outdoor unit	Connection wires
22.0	SAD80D1-A	380V-415V~,3N,50Hz	3×1mm ²	5×6mm ²	2×AWG22
28.0	SAD100D1-A				

Notice:

- ◇ Above mentioned power supply cord is the cable which connect air on-off of indoor to indoor/outdoor unit. Power supply cord of indoor/outdoor unit is the power supply cable connecting indoor and outdoor unit
- ◇ The section area of power supply cord core is minimized one. To avoid voltage pressure dropped down, while longer power supply cord needed, the section area should be enlarged for one gauge.
- ◇ The connection wires to indoor unit is the cable of 27IEC53(RVV) type, 300/500V; while the connection wires to outdoor unit and the connection wires from outdoor to indoor unit is the multi-end of cable (neoprene)of 245IEC57(YZW)type,300/500V. if the single core with double skin type of cable is chosen for installation,, please choose 1# gauge of section area and wrapped with special jacket for electrician.
- ◇ All of the ceiling/floor type unit is without accessorial electric heating

7.3.3 wire connection

Remove electric control box cover of indoor unit, connect the wires in accordance with the electri diagram mentioned on the back of the cover. The wire ends must be tightly fixed into terminal boards without ease. The earth wire must be fixed into appointed position.

Outdoor wire connection

- ◇ Remove the electric item cover, which is positioned in the right side of outdoor unit, connect the wires in accordance with the electric diagram on the back of the cover.

- ◇ Be sure that pressing the wires tightly with the terminal boards while it through the board, the wire ends must be tightly fixed into terminal boards. The earth wire must be fixed into appointed position.
- ◇ After all the wire connected, bundle connection pipe, connection wires and drainage pipe with strips like mentioned drawing below:

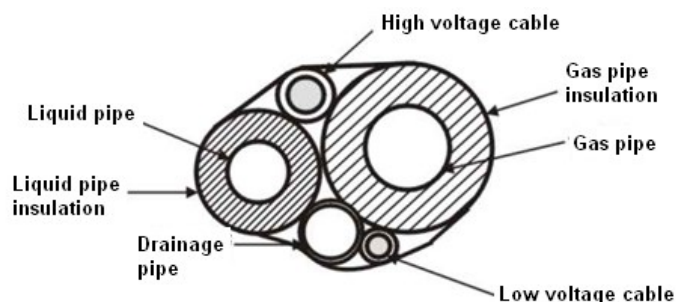

Notice:

- ◇ Compressor of AL-H80/5R1S(FS), AL-H100/5R1S(FS), AL-H80/5R1S(HD), AL-H100/5R1S(HD) are 3 phase power supply with phase sequence protection in its outdoor control board. Please be careful with wire connection.
- ◇ Be sure do't make the drainage pipe flat while bundled.

7.4. Commissioning

After installation, machine can be started commissioning.

Check installation condition

- ◇ Check indoor/outdoor unit installation and wire connection in accordance with the requirement of service manual.
- ◇ Check the power supplying, diameter of wires, air on-off and make it sure that the items can be matched with machines and, earth wire connection safety.
- ◇ Check air inlet/outlet duct and make it sure that the items is clean, operating smoothly.

Commissioning

- ★ During winter, the first run of performance should be supplied power 8 hours in advance to warm-up the crankcase.
- ★ During winter, while after 8 hours power off, the performance test should be 2 and half hours power on later:
 - ◇ Power on, run machine with cooling mode.
 - ◇ After 3 minutes compressor protection, check if there is normal cooling air come from indoor unit and if there is abnormal noise come from indoor/outdoor units
 - ◇ Configure the mode with "fan" and check if there is high air come from indoor unit.
 - ◇ Operate "swing" mode, check if the louver is properly swaying.
 - ◇ Press the other buttons on the remote controller and check if the complete unit is on proper working condition
 - ◇ Operate machine 1 hour with "cooling" mode and check if the drainage system is on proper condition
 - ◇ Switch the mode for "heating" and check if there is warm air come from indoor, if there is abnormal noise come from indoor/outdoor units
 - ◇ After confirmation of normal working condition, press the "on-off" to stop running machine.
 - ◇ Then and there, train the end users with operation, maintaining and special notice.

7.5. Compressor freezing oil brand and standard oil charge

Outdoor model	Brand	Compressor Model	Compressor Lubricating Oil Model	Oil charge (cm ³)
SAU80D1-A	LanDa	QXAS-H49SN330	B68EP /FVC 68D /FV 50S or equivalent	1500
SAU100D1-A	LanDa	QXAS-H49SN330	B68EP /FVC 68D /FV 50S or equivalent	1500

7.6 Daily maintenance

Clean inhaler

- ◇ Before cleaning the filter, ensure the unit is switched off and the power is off;
- ◇ Forbidden to use water clean the filter , it will hurt PCB or get an electric shock;
- ◇ When cleaning filter net, be sure you are standing steady, if you use ladder or others, please be careful.

Washing filter net

- ◇ Use vacuum or water to clean the net;
- ◇ In order to ensure the best performance from your air conditioner clean the air filter regularly
- ◇ We recommend cleaning once a month or more frequently if required.
- ◇ When the filter is very dirty it can be washed in detergent and hot water (below 45°C);
- ◇ Ensure the filter is fully dry before reinstallation to avoid risk of electric shock or short circuiting;
- ◇ Do not dry the filter using direct sunlight;



Check at the beginning of each season

- ◇ Check whether there are no physical obstructions at the air inlet or outlet of either indoor or outdoor unit;
- ◇ Check whether there are some garbage at the water outlet;
- ◇ Check whether electrical cables are in good condition, particularly the earth cable;
- ◇ When power on, check weather letters display on the screen of the wired controller.
- ◇ When working in winter, must connect power for 8 hours before switch on unit.

Check at the end of service season

- ◇ Operate for 2 3 hours under the ventilation condition; remove the moisture of the indoor unit.;
- ◇ If not use air conditioner in a long time, please close the power to save energy, the letter will disappear on wired controller;
- ◇ Take the batteries out of remote controller;
- ◇ Suggest that use dustproof to cover the outdoor unit;

Part 3 Trouble shooting

1. Main components of air conditioner	35
2. Electrical system main components	38
3. Poor efficiency explanation	40
4. Failure phenomenon	41
5. Electric components malfunction inspection	41
6. Failure code display	42
7. Failure analysis	45

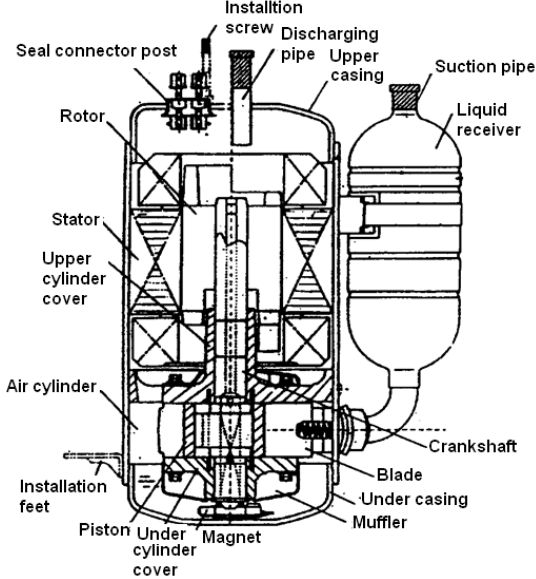
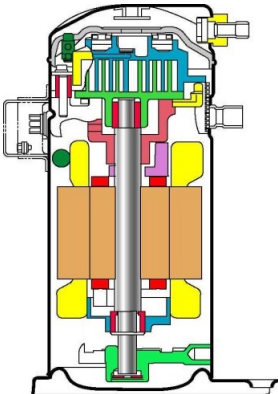
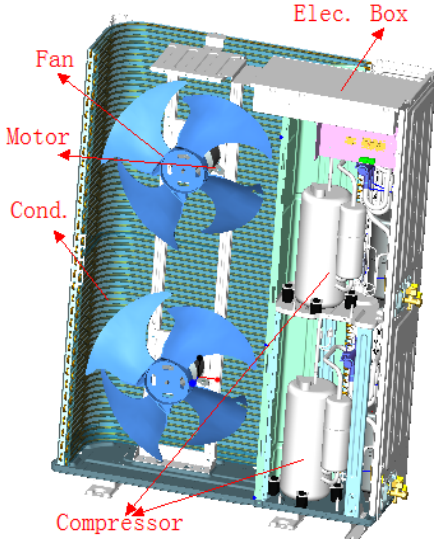

1. Main components of air conditioner

Appellation	Figuration and inner configuration	Instruction
<p>Rotary compressor</p>		<p>The function of compressor: after refrigerant evaporate in evaporator, compress the low temp and low pressure refrigerant gas, make the gas become high temp and high pressure gas, and then send the gas to condenser, make the refrigerant cycle, in this series products, all the compressors are complete hermetic compressor, in which motor and compressor are together.</p>
<p>Scroll compressor</p>		
<p>condenser (heat exchanger)</p>		<p>The function of condenser: Make the high temp and high pressure refrigerant gas discharged by compressor become liquid [make the gas heat exchange with air], (mark: when heating, condenser become evaporator)</p>

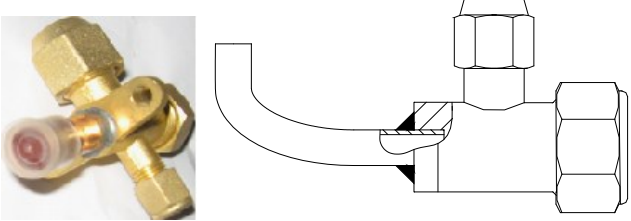
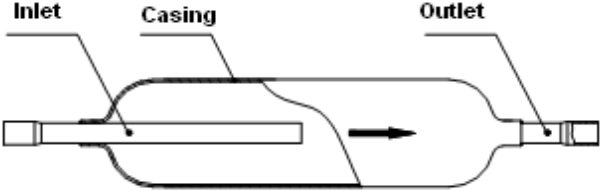
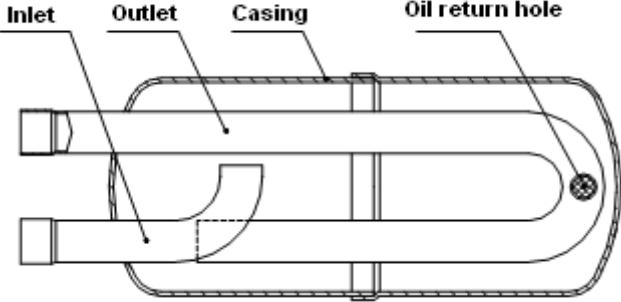
<p>Evaporator (heat exchanger)</p>		<p>Function of evaporator: Make the low pressure refrigerant liquid from capillary or expansion valve happen heat exchange with air</p>
<p>Capillary (throttle components)</p>		<p>Function of capillary: Utilize aperture and length change bring pressure gap., control refrigerant flow quantity and pressure</p>
<p>One way valve</p>		<p>One way valve is used for heat pump unit, it make the refrigerant liquid only flow as the arrow direction</p>
<p>Four way valve</p>		<p>Function of 4 way valve: When change cooling mode into heating mode, it will change the flow direction of refrigerant; When heating, the valve get electricity (cooling without electricity), the slip assembly move to the right connect pipe 2 and 3, so change the flow direction.</p>

<p>Stop valve</p>		<p>Function: To stop or release refrigerant, only on/off, can't adjust or throttle</p>
<p>Muffler</p>		<p>Function: Eliminate the system noise</p>
<p>Gas and liquid separator</p>		<p>Function: Separate liquid and gas refrigerant, to protect the compressor</p>

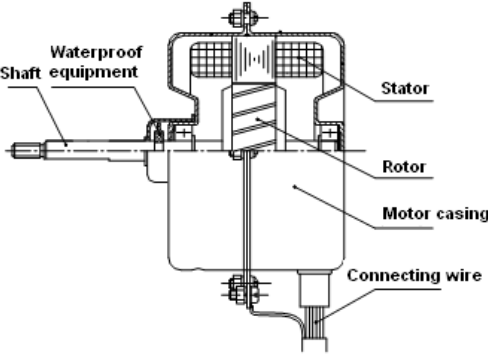
2. Electrical system main components

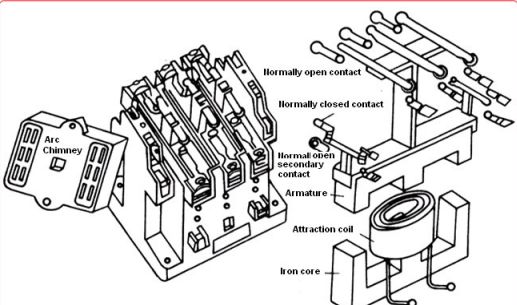
Appellation	Figuration and inner configuration	Instruction
PCB		<p>Function:</p> <p>Via program to control the relay, make every components on/off according to temperature and pressure variety, so to realize automatic control</p>
Fan motor		<p>Function:</p> <p>Drive the fan, make the indoor and outdoor unit have heat exchange with air.</p>
Pressure switch		<p>Function:</p> <p>To avoid the air conditioner work in a abnormal pressure, making the air conditioner work safety.</p>
Capacitor		<p>Induce the single-phase motor produce gyre magnetic field, connect with the accessory winding, and participate in the operation.</p>
AC Contactor		<p>When AC contactor's inner magnetic loop without power, the counter force of spring and the weight of armature core will make the main connector disconnect, when the magnetic loop with power, it will make the main connector connect, the power is on, accessories contactor will act.</p>

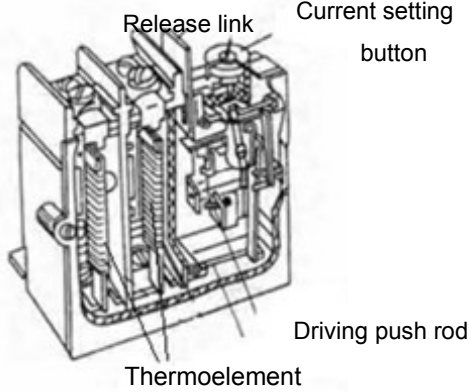
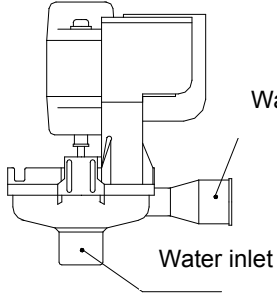
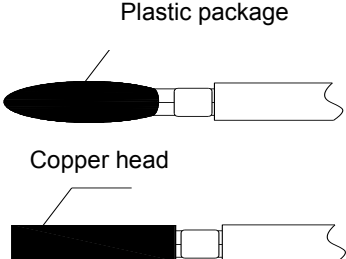
<p>Heat relay</p>		<p>Heat relay is normally made up of double metal sheet, when the current is too large, the double metal sheet will heat distortion and movement, and open the protection contactor, which causes control circuit disconnect and then the main circuit will be cut off, after it cooling, control circuit will restore connection, but the main circuit is still disconnect, need to press start button to restart unit,</p>
<p>Condensate pump</p>		<p>Only for Cassette, the pump head is 1.2 meter, the condensate pipe must have over 1/100 descend angle, after unit cooling or dehumidify stops running, the pump will still work 3 minutes to clean the condensate.</p>
<p>Sensor</p>		<p>Physical properties will change along with the temperature, pressure change, used for check temperature and pressure.</p>

3. Poor efficiency explanation

During the process of using air conditioner, some phenomenon seems to be malfunction but actually not. Thus when cooling effect does not achieve to your expectation, the following factors have to be ruled out

Phenomenon	Causing explanation
High outside temperature and too many indoor individuals, even air conditioner runs at full-load operation, the wind blowing out from air outlet is cold, but it is difficult to lower the indoor temperature, this is not malfunction.	When the outdoor temperature is higher, more heat penetrates into indoor space, which increases the cooling load of AC. If there are too many individuals(for example 10 individuals) and every individual gives off 120W, totally 1200W, this will running out of half of AC cooling capacity, and the unit's cooling capacity this time is far from enough, indoor temperature is hard to lower down. It is normal phenomenon and do not mean useless of AC.
Power voltage is too low, causing AC uneasy to start and shut down after starting, or fuse be burned out etc.	It is not malfunction, need to find out the causing, if the causing is the electricity net voltage is too low, user should load a power manostat to keep voltage between 220V-380V for AC normally running
Select high wind speed but indoor temperature still at high side, air flow from the air outlet is too weak.	It is because air filter is too dirty or blocked making cooling capacity fail to be brought by air flow, causing cooling capacity inadequate. Take out filter and wash, the problem will be solved.
Select high wind speed, the vibration and sound of unit are severe.	Fan runs at high speed, severe vibration and sound of unit is normal phenomenon
Temperature controller adjusts improper and max cooling capacity is not utilized completely, thus indoor temperature can't lower down.	Adjust the temperature controller, and problem will be solved.
As for Heat pump air conditioner heating effect is not ideal during cold winter, this is normal phenomenon.	The lowest temperature is -7°C when heating, below this temperature unit cannot heat effectively.
Improper installation will lead to indoor temperature uneven or bad cooling effect.	It is necessary to adjust AC installation position

4.Failure phenomenon

Phenomenon	Causing explanation
Mirage comes out from indoor unit	When the cold air from AC cools the indoor air
Noise	<ol style="list-style-type: none"> 1. When air conditioner stops running, there will be some noise, and this is because the refrigerant flows contrarily. 2. AC expand or shrink according to temperature, causing harsh sounds 3. Liquid sound is from refrigerant flowing
Sometimes, the room is smelly	<ol style="list-style-type: none"> 1. The AC itself will not be smelly, if it is smelly, it is because environment smell accumulated 2. Solution: clean the filter
when heating, there is no wind at the beginning of starting unit	<ol style="list-style-type: none"> 1. It is to prevent cold air blowing, please be patient 2. The unit has auto-restart function, when it is repowered again, unit will run according to the mode which is set before the power off. (Note: default is closed)

5. Electric components malfunction inspection

No	Component name	Inspection methods
1	Compressor	Using multi-meter ohm phase, there is correct resistance value among windings (single phase compressor refers to specification, three phase compressor resistance approximately equal), resistance of winding should be infinite.
2	Control board	1. Check if any connection part of PCB loosen or drop off, printed tinsel and components have any burn, fade, breaking off or aging phenomenon, all joints exist short circuit phenomenon etc. 2. Test the circuit board system in the term of voltage, pulse on, resistance variation, by using testing meter. 3. Judge the output and input is normal or not according to electric principle diagram
3	Contactor	4. Press the contactor by hand, the contactor reacts immediately and without question 5. The contacting point of contactor has no burn and melt phenomenon 6. The winding has resistance value below 1000, but cannot be nil or infinite
4	4-ways valve winding	The winding has resistance value below 1000, but cannot be nil or infinite
5	Capacitor	7. No expansion phenomenon apparently 8. Measure capacitor by using capacitor phase of multi-meter(if the multi-meter has no capacitor phase, use ohm phase, contact the two terminal of meter to two feet of capacitor, and quickly switch positive pole and negative pole and reconnect, the resistance should display from nil to infinite quickly. The resistance can't change is always nil or infinite).
6	Sensor	9. Using multi-meter to measure resistance, find out temperature according to resistance table, the temperature should accord with sensor temperature. 10. Resistance cannot be nil or infinite
7	Motor	11. No burning trace apparently 12. Using multi-meter ohm phase, there is correct resistance value among windings (single phase compressor refers to specification, three phase compressor resistance approximately equal), resistance of winding should be infinite.

6. Failure code display

When air condition has failure, the timing lamp on light board of controller will display different code according to different failure case.

6.1 1Unit failure code for Air floor standing type

Failure causing	Display 1 (lamp panel)	System1	System2
Failure of indoor and outdoor units	F1	All wind icons keep quenching	
Indoor temperature "TA" is abnormal	E1		
ODU failure of three phase	E6		
Digal switch error	F7		
IDU ambient temperature is abnormal	F8		
ODU ambient temperature over temperature	F5	Wind icon bright one grid	Wind icon bright one grid
High pressure protection	EH		
Low pressure protection	EL		
Lack of fluoride protection	E0		
Indoor coil "TE" is abnormal	E3		
Defrosting temperature is abnormal	E2		
Outdoor coil "Tcm" is abnormal	E7		
Discharge "TP" is abnormal	E8		

6.2 Unit failure code for High static pressure type

FAult	Display type line controller	Display TypeReceiver	Display type power light	Phenomenon
Failure of indoor and outdoor unit	F1	Blinks 5 times, stops 2 seconds	Bright	stop
Indoor unit temperature "TA" is abnormal	E1	Blinks 1 times, stops 2 seconds	Bright	stop
ODU failure of three phase	E6	Blinks 6 times, stops 2 seconds	Bright	stop
Digal switch error	F7	Blinks 7 times, stops 2 seconds	Quench	stop
IDU failure of three phase	F8	Blinks 8 times, stops 2 seconds	Quench	stop
ODU ambient temperature is abnormal (Tdef)	F5	Blinks 5 times, stops 2 seconds	Bright	non-stop
Discharge temperature protection	F2	Blinks 2 times, stops 2 seconds	Bright	stop

High pressure protection	E9	Blinks 9 times, stops 2 seconds	Bright	stop
Low pressure protection	E9	Blinks 9 times, stops 2 seconds	Bright	stop
Lack of fluoride protection	E0	Blinks 11 times, stops 2 seconds	Bright	stop
Indoor coil temperature sensor is abnormal	E3	Blinks 3 times, stops 2 seconds	Bright	stop
Defrosting temperature is abnormal (Tdef)	E2	Blinks 2 times, stops 2 seconds	Bright	stop
Outdoor coil "Tcm" is abnormal	E7	Blinks 7 times, stops 2 seconds	Bright	non-stop
Discharge temperature "TP" is abnormal	E8	Blinks 8 times, stops 2 seconds	Bright	non-stop

Note: When correct signal has not been received by wired control or main control board in 2 consecutive min, then the unit turns off and indicates relative failure code, once communication renew and failure code disappears automatically.

7.Failure analysis

Wired controller communication failure

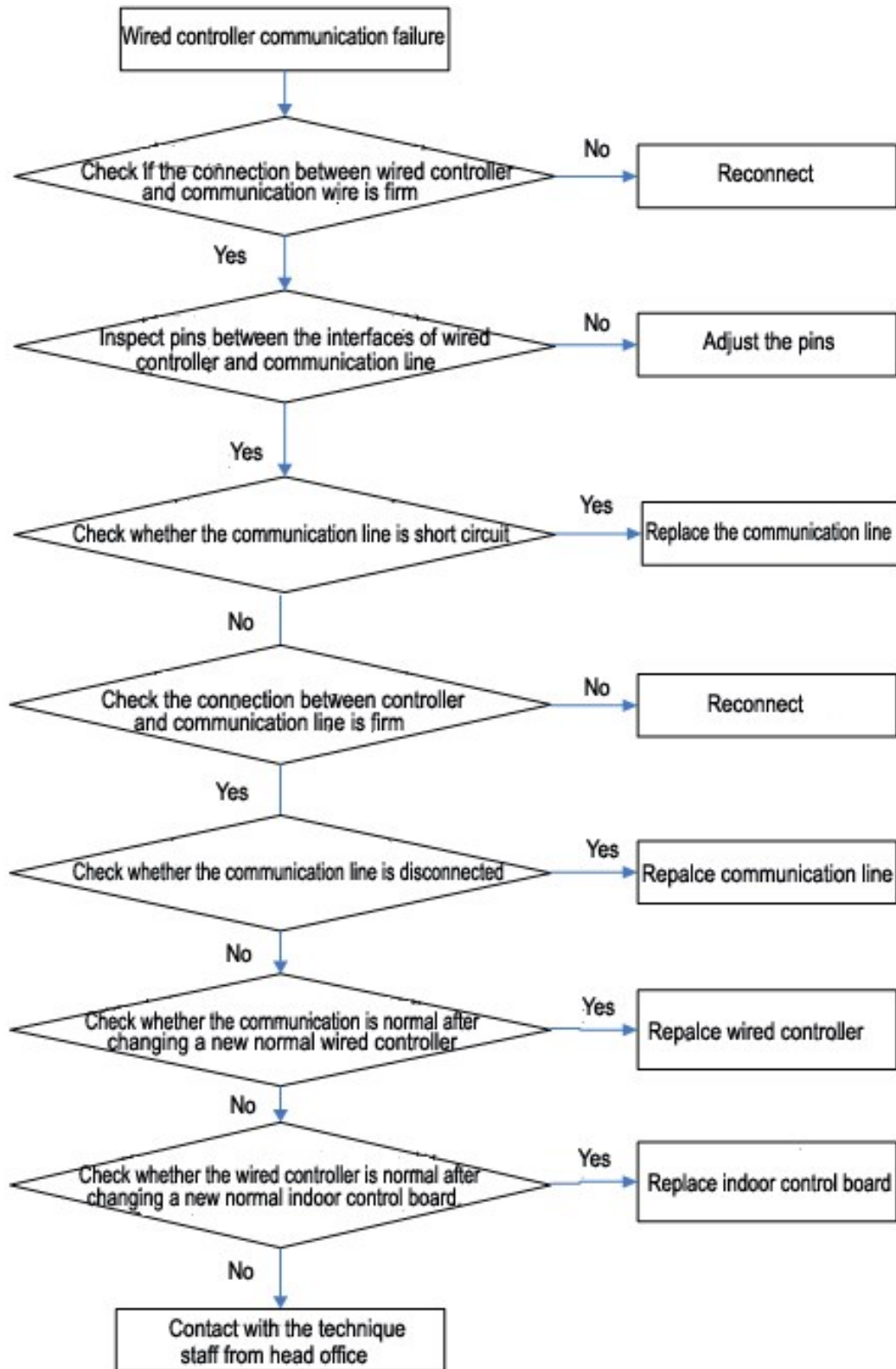

Communication failure between indoor and outdoor unit

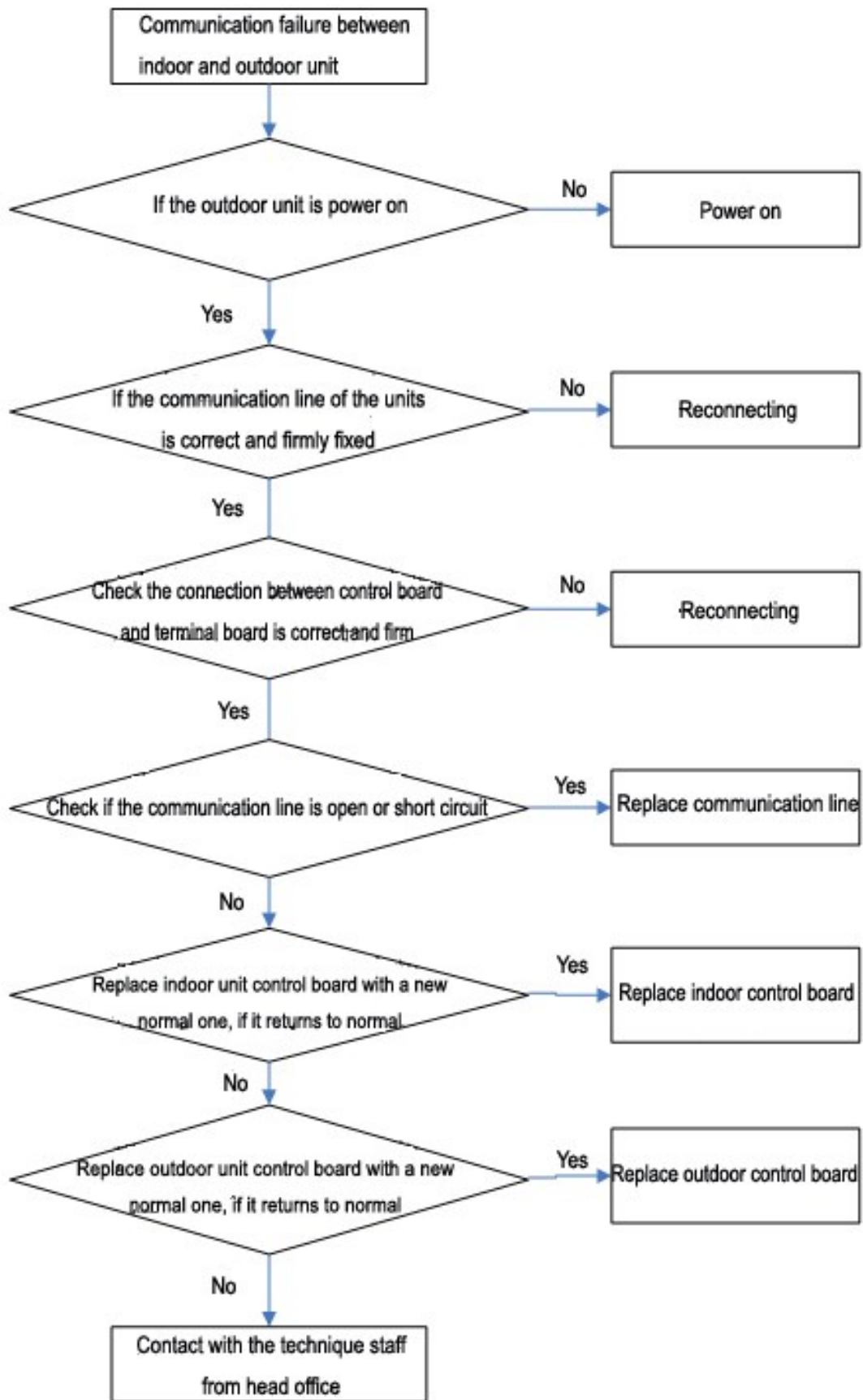

Outdoor protection(phase sequence)

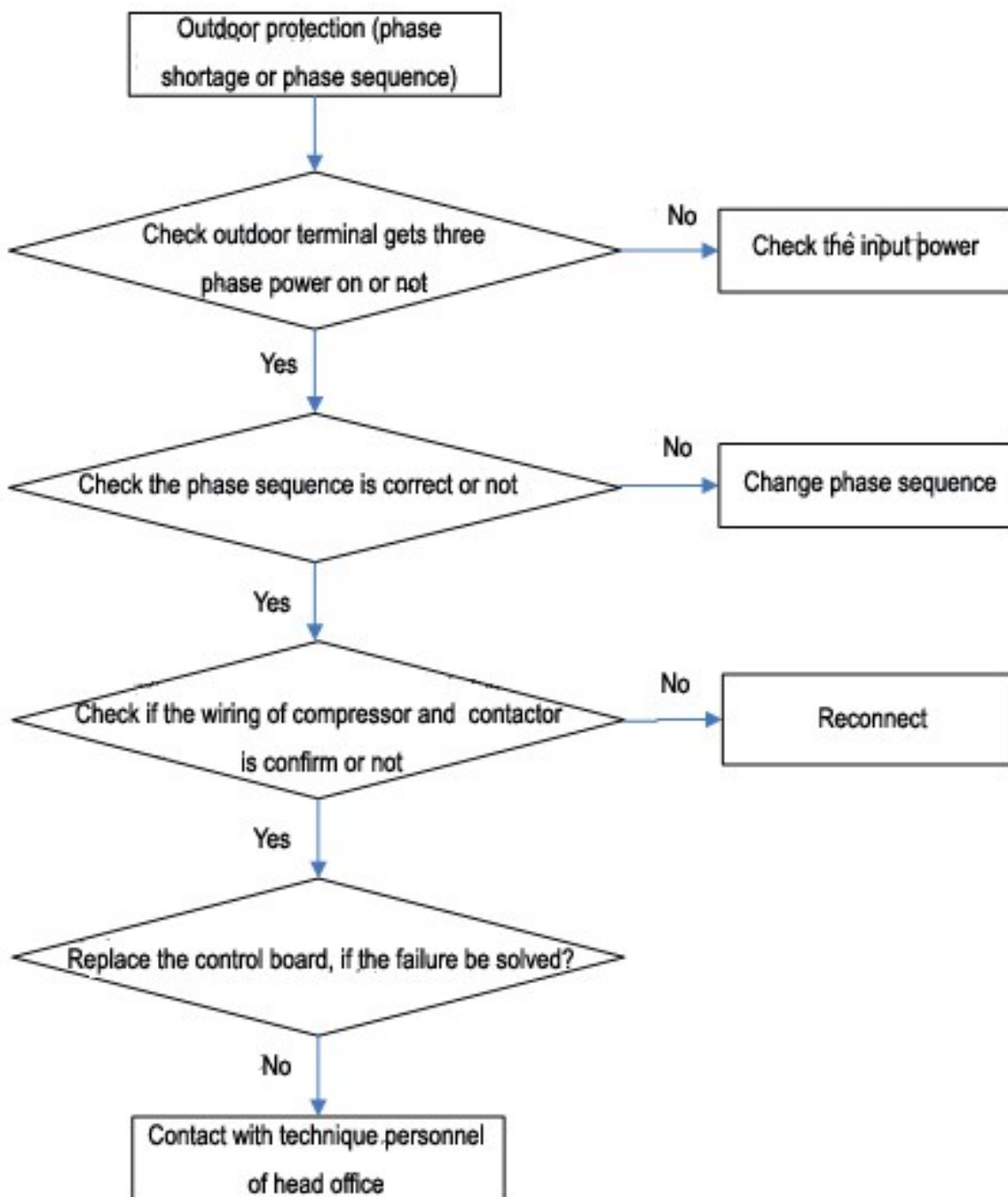

Cooling high pressure protection

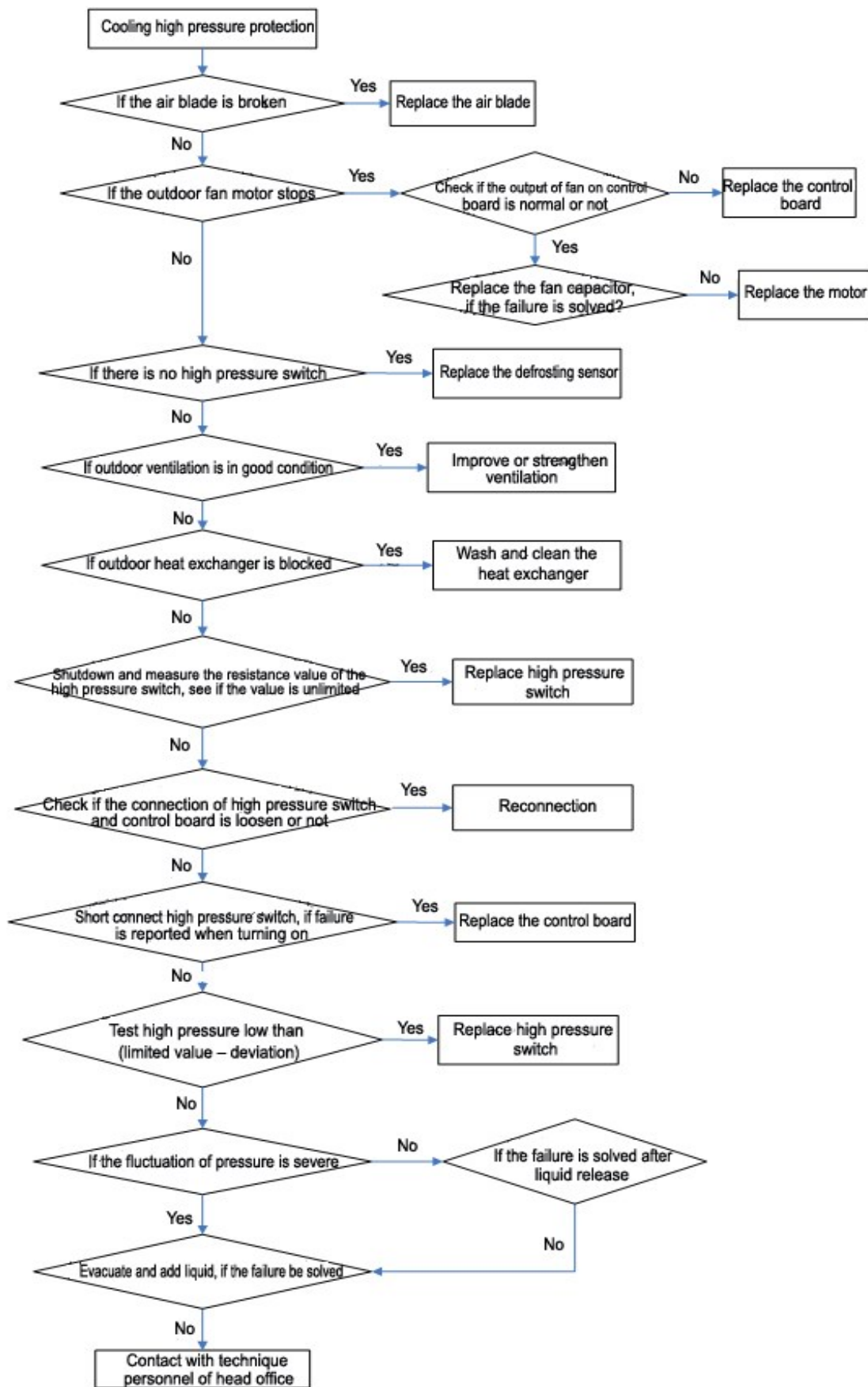

Heating high pressure protection

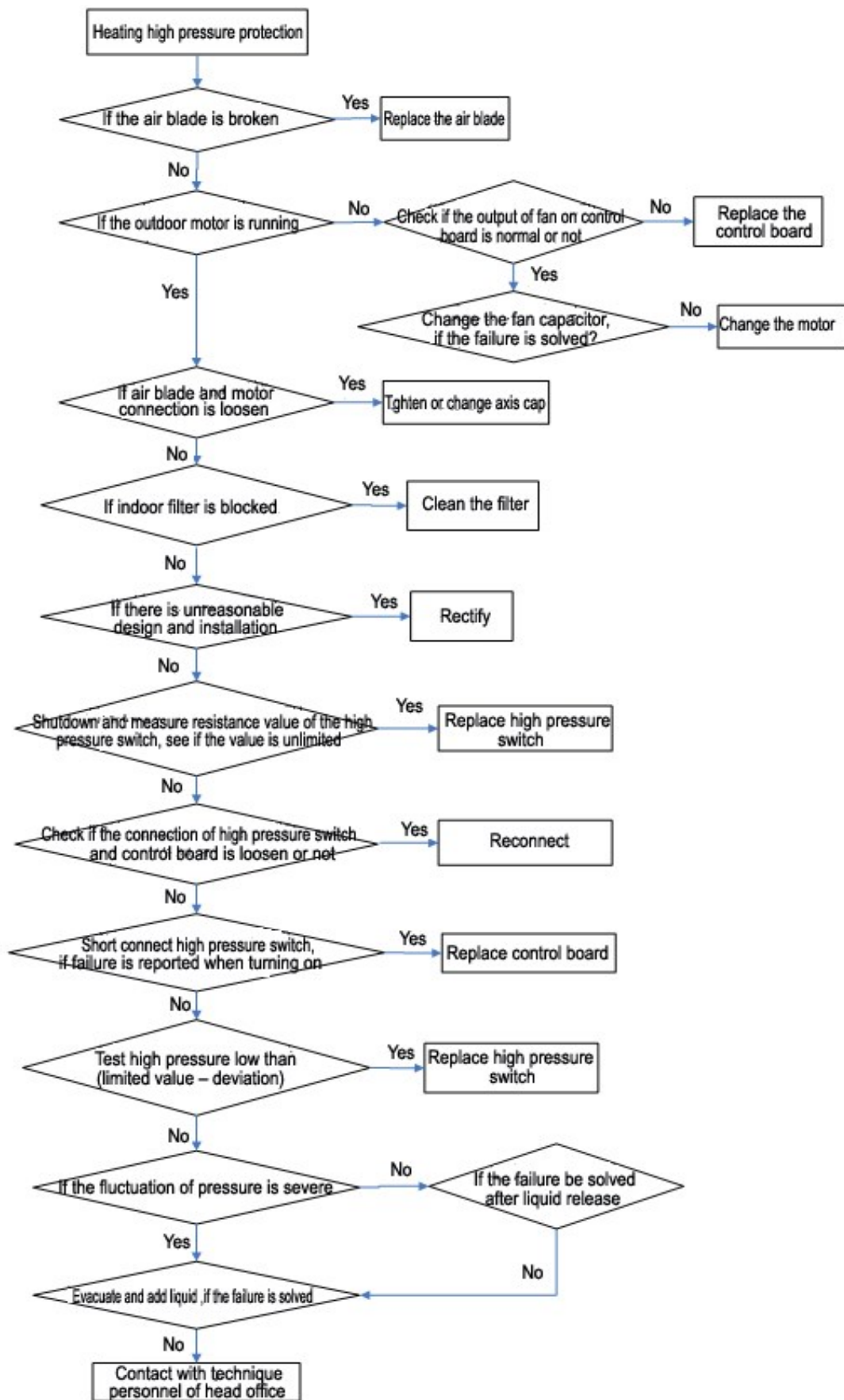

Cooling low pressure protection

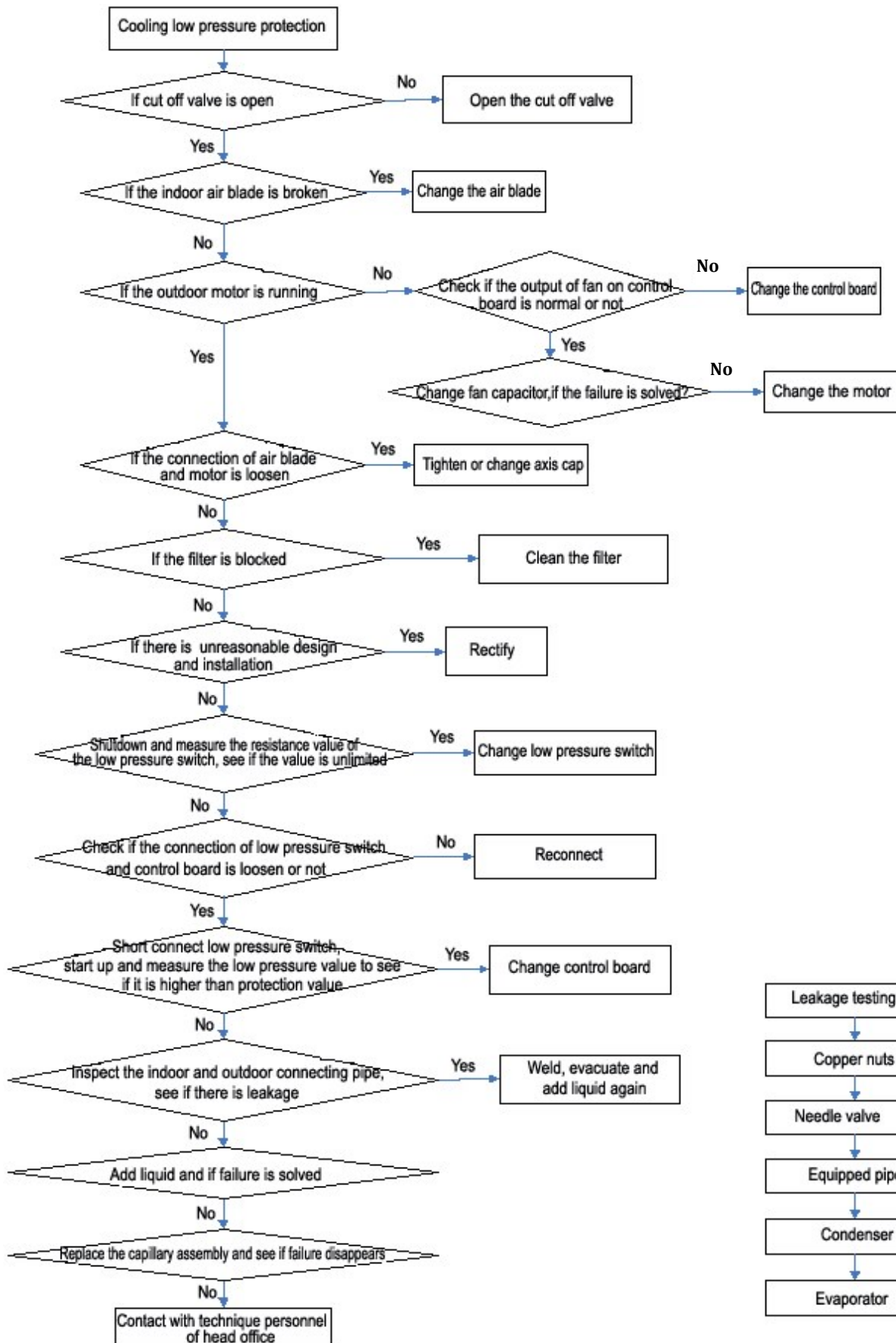

Heating low pressure protection

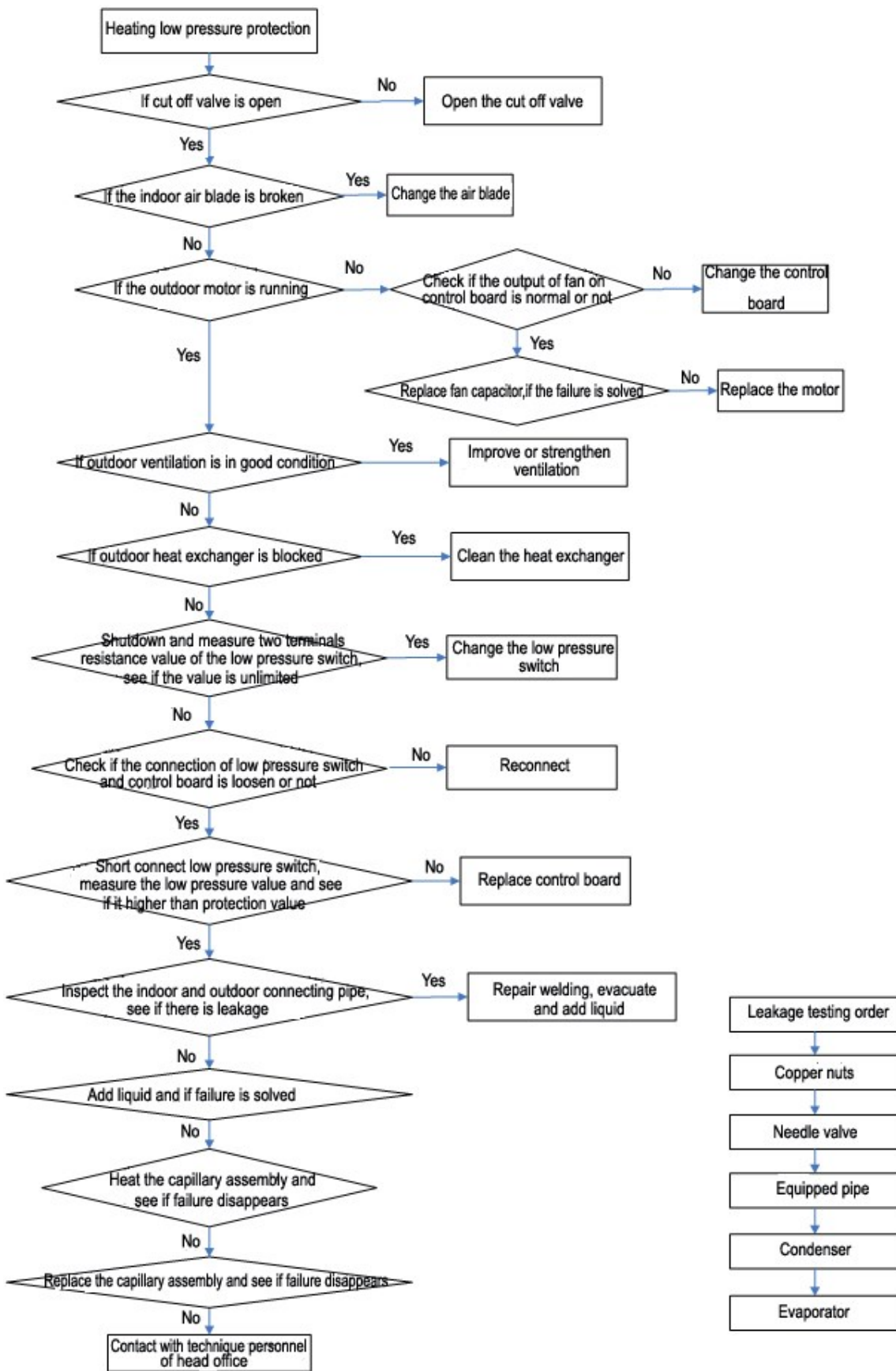

Cooling exhaust temperature protection

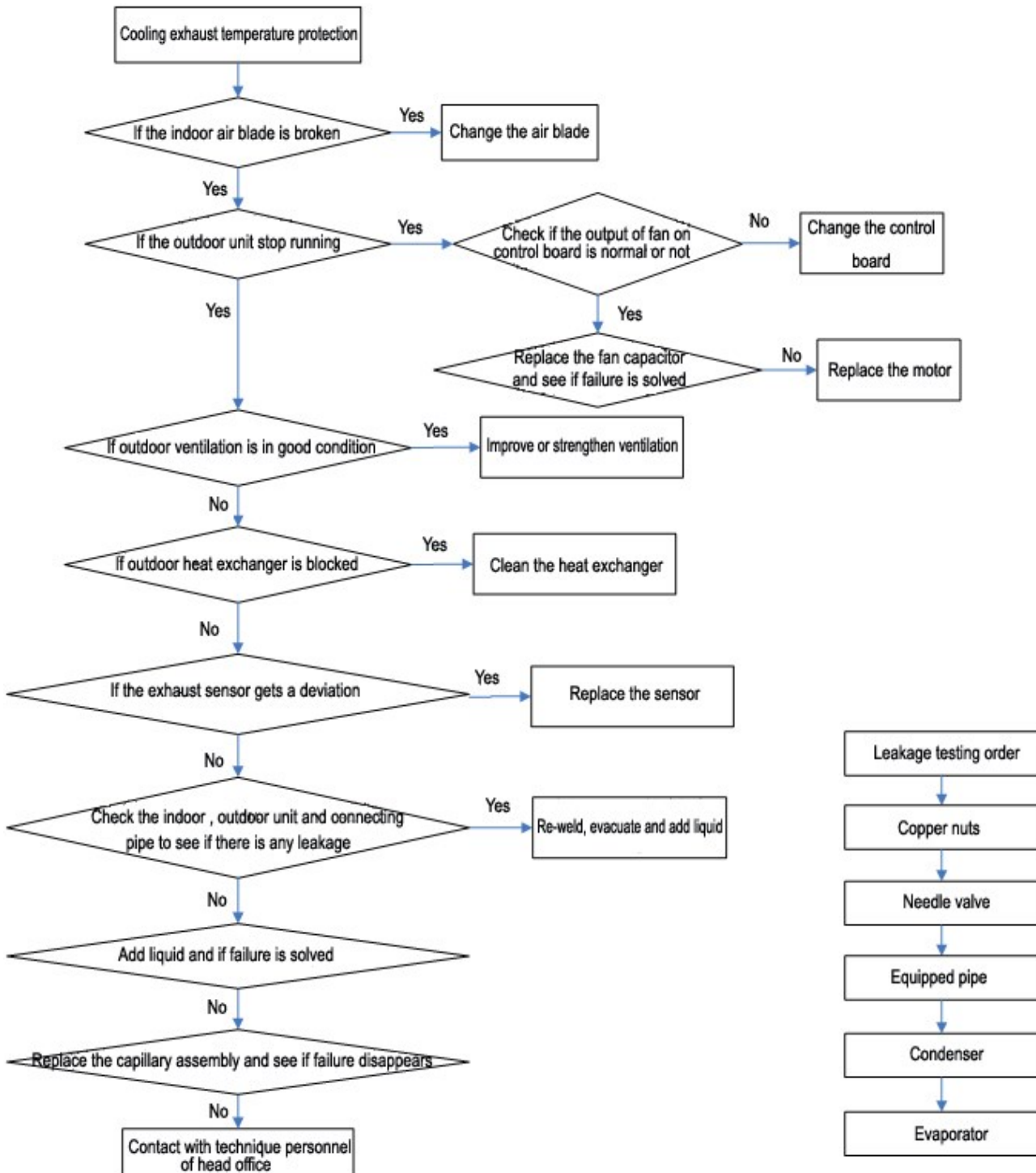

Heating exhaust temperature protection

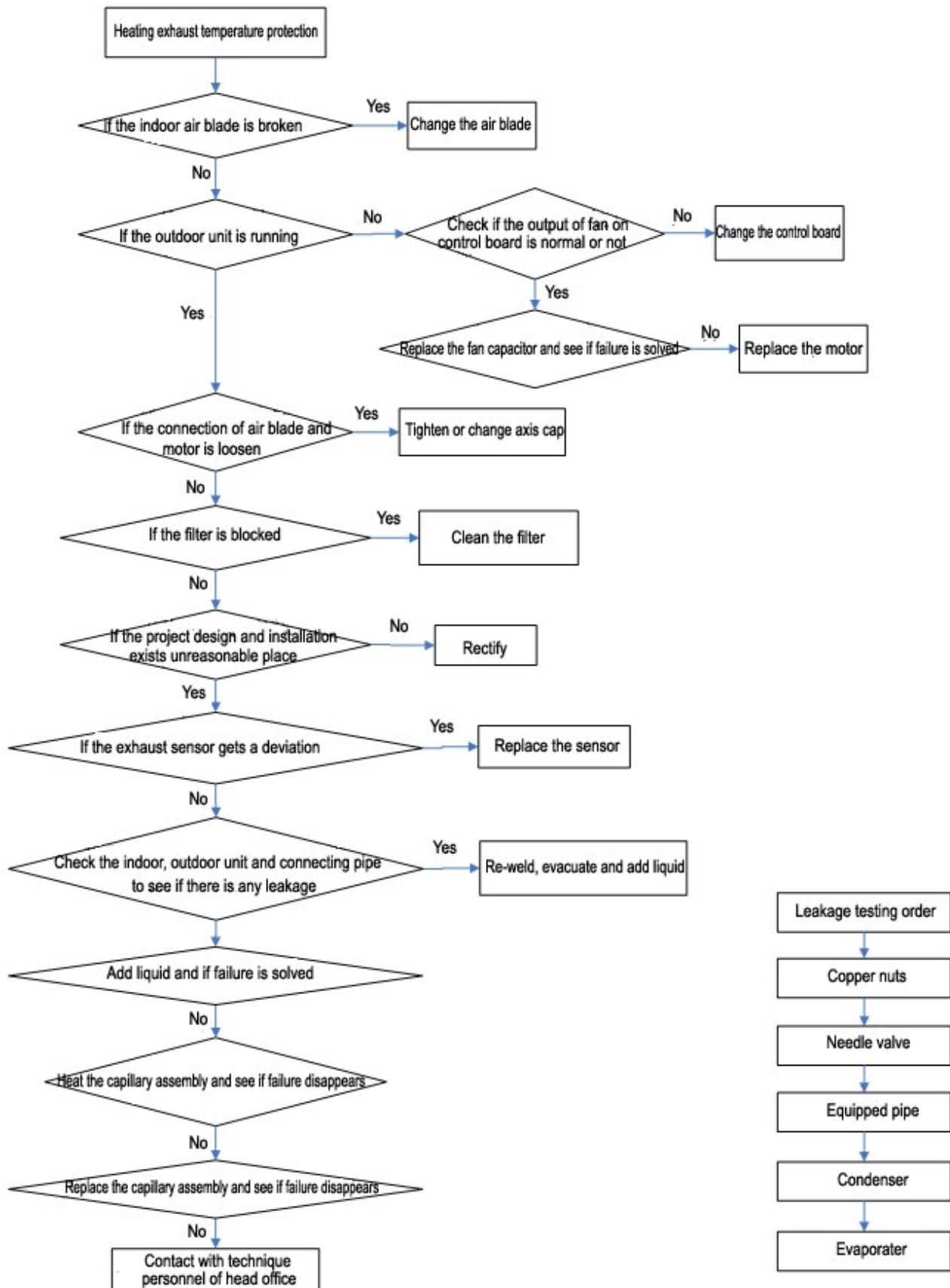

Refrigerant shortage or four way valve failure protection

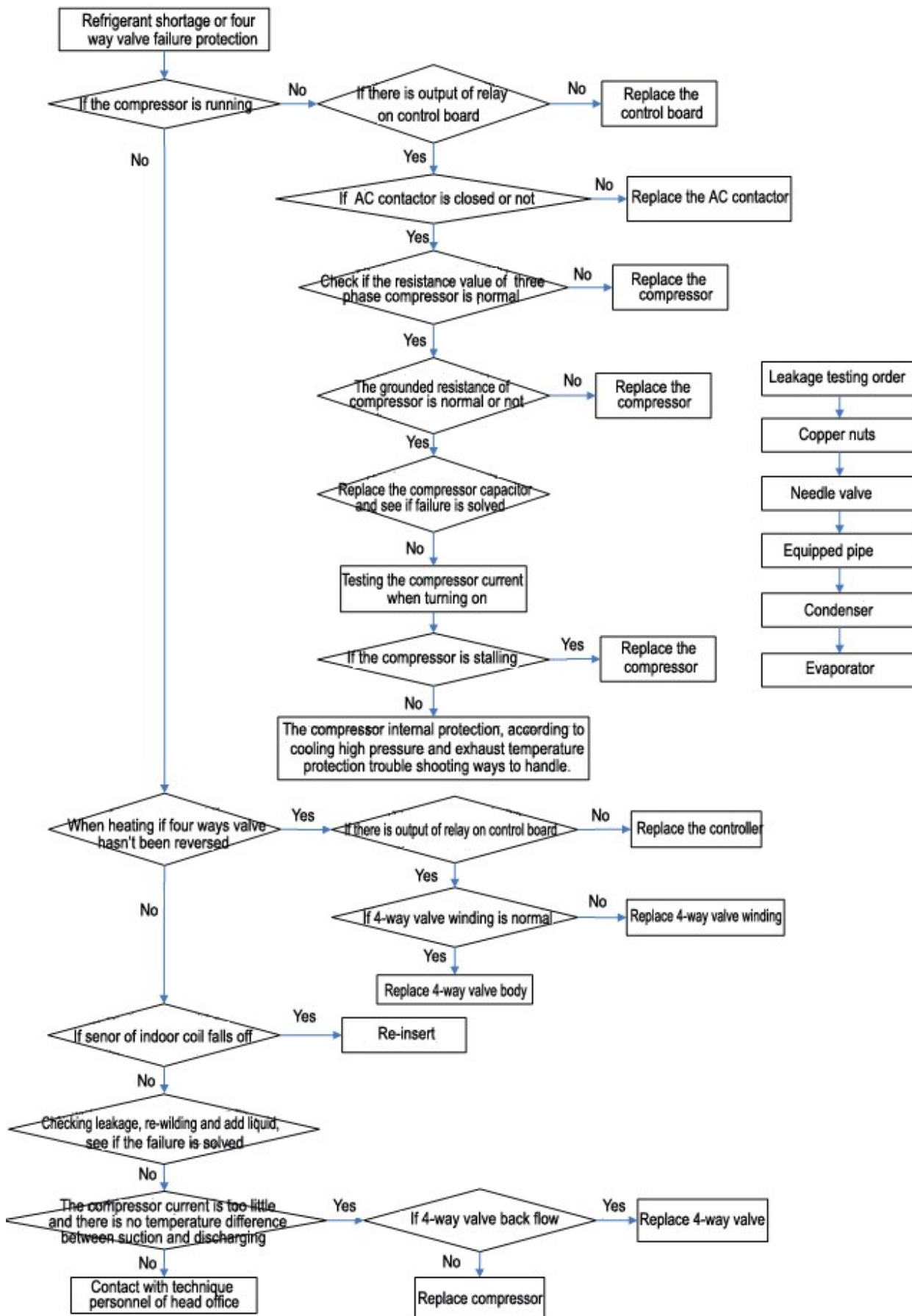

Sensor failure protection

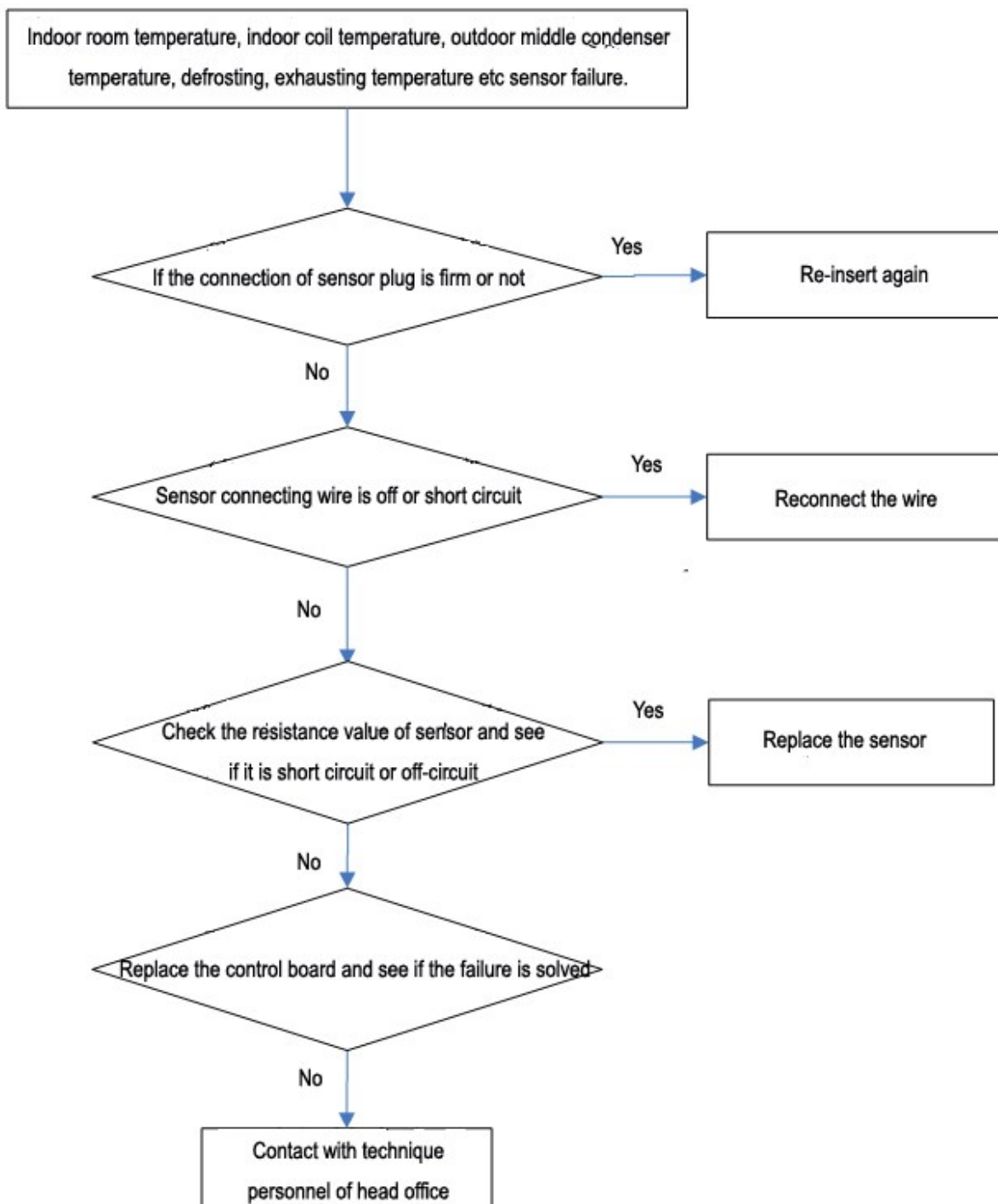

No action after power-on



Cooling or Heating Poor effect

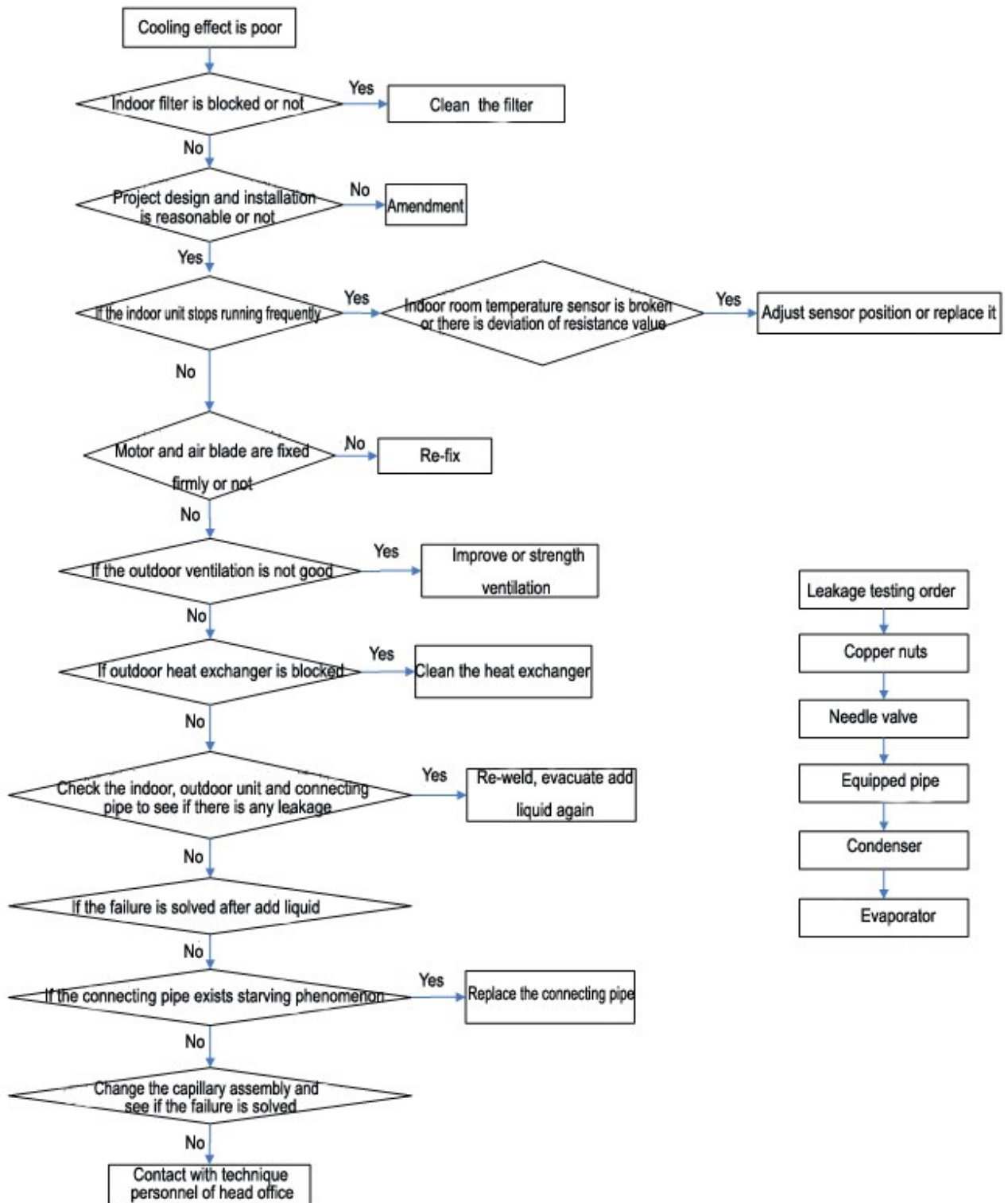

Abnormal sound or vibration

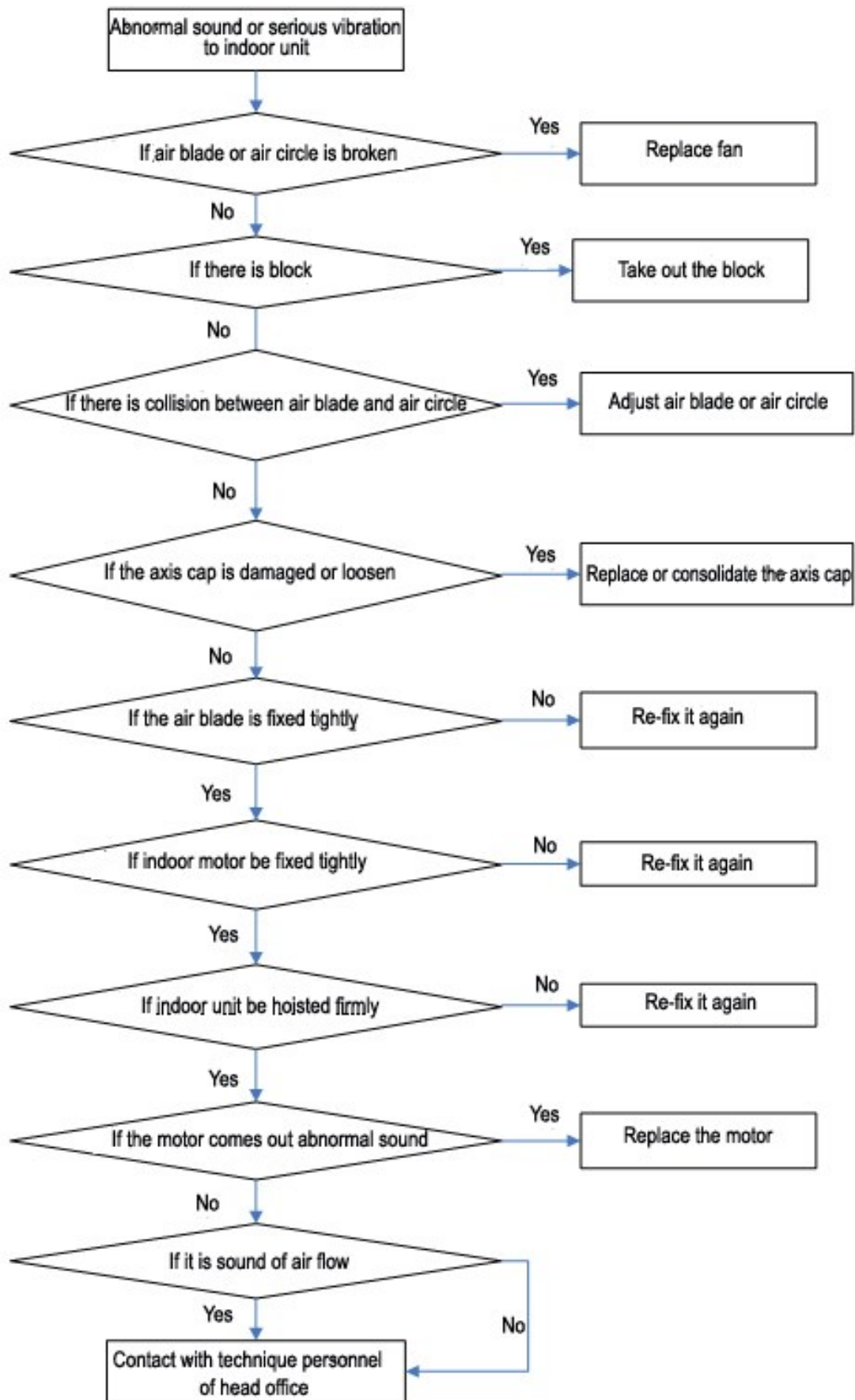

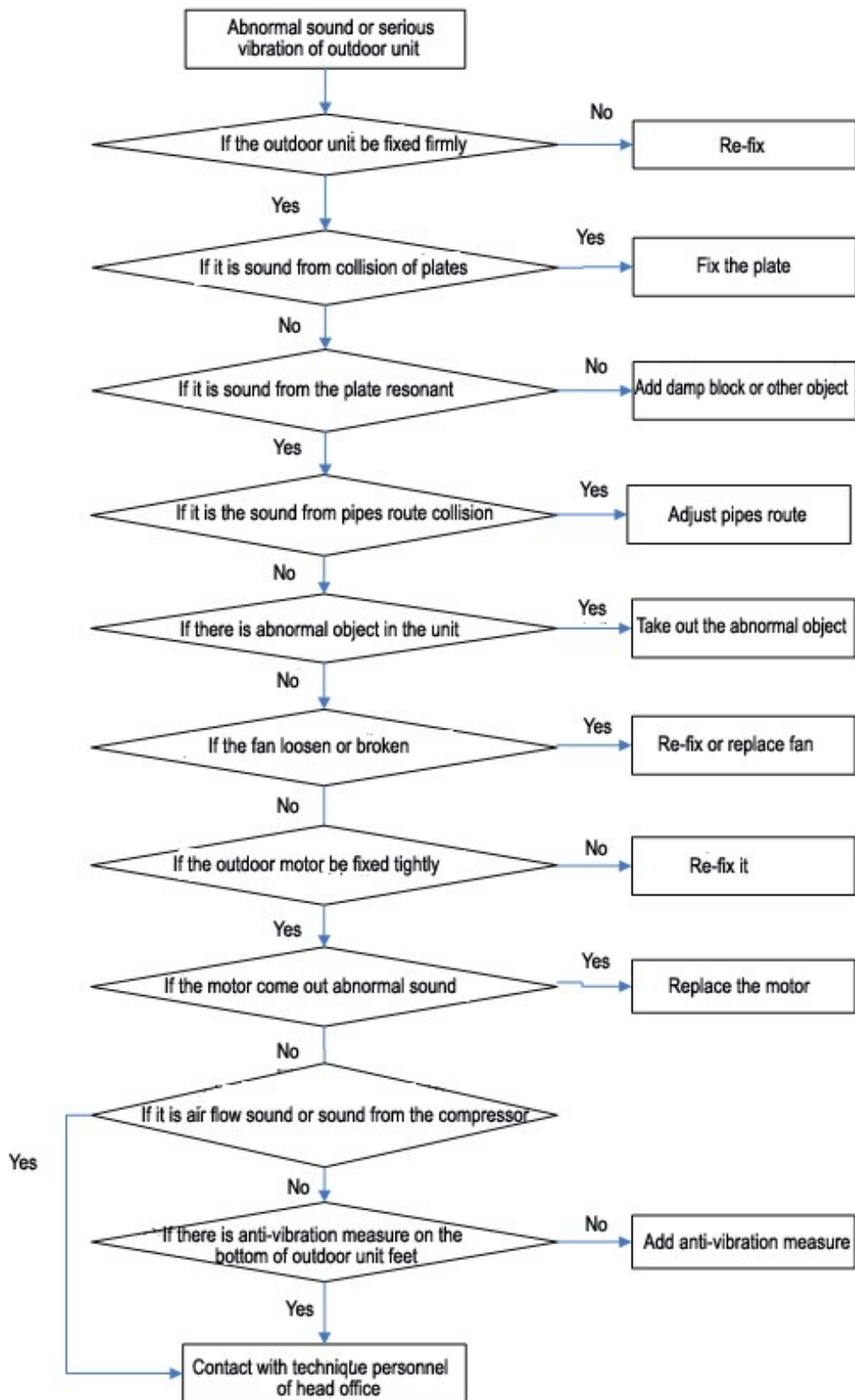

Abnormal odor

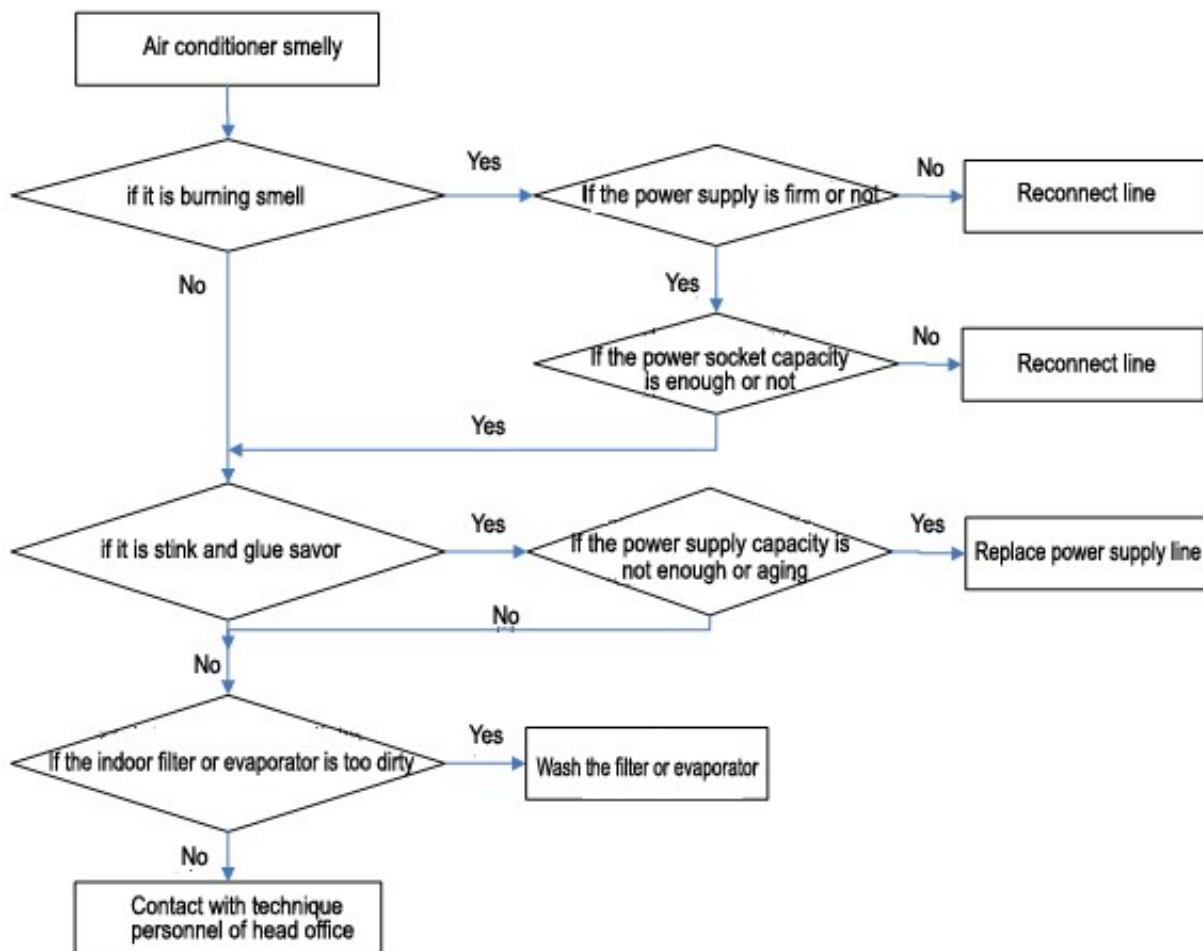

Air switch action when air conditioner starting up

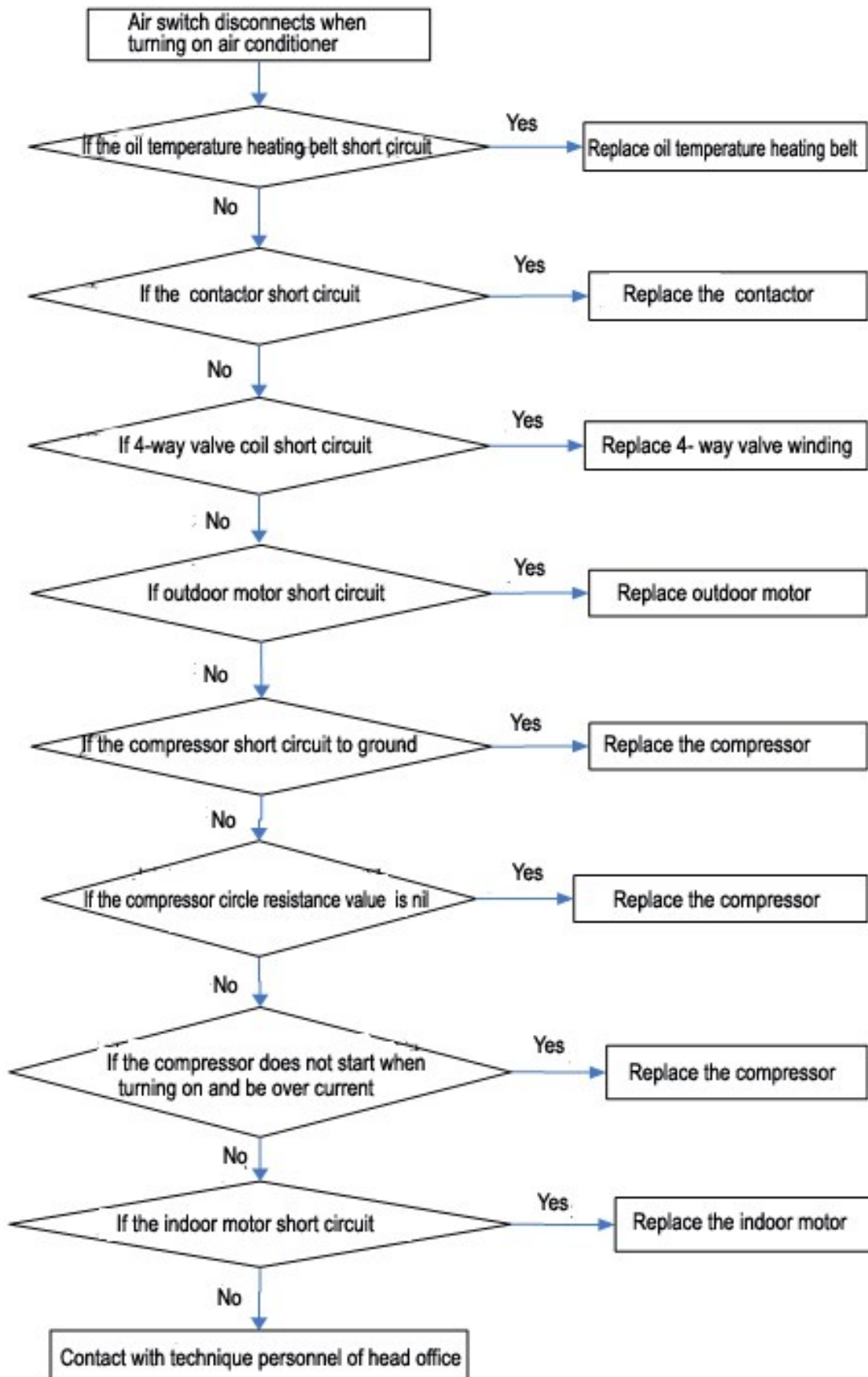

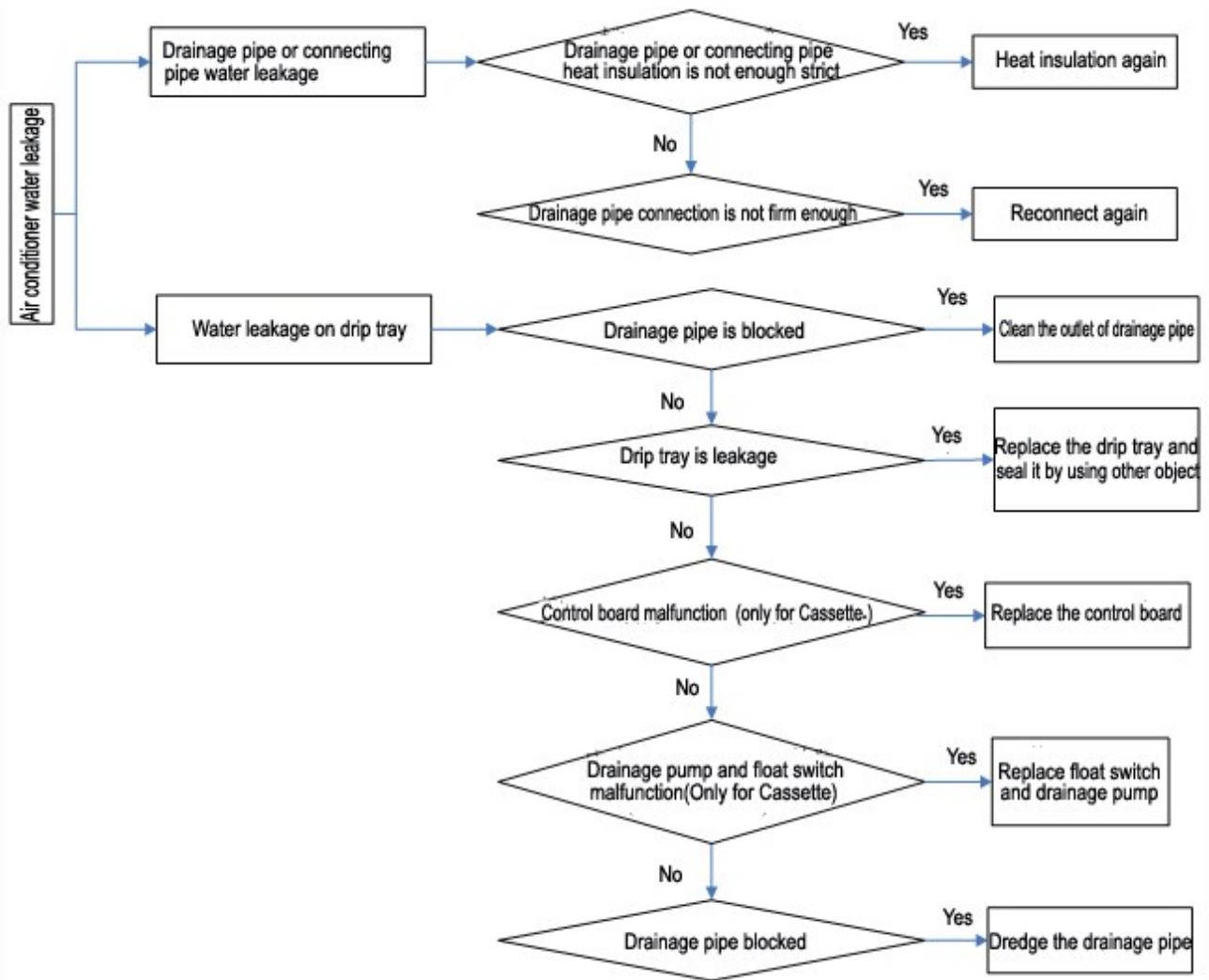

Air conditioner water leakage



Part 4 Controller

1.General information

Remote controller, wired controller, display panel and receiver

Remote controller, wired controller, display panel and receiver				
	Available for all models	Available for all models		Available for Duct indoor unit
Note	<p>For Cassette and Ceiling & Floor indoor unit, remote controller is standard and wired controller is optional.</p> <p>For Duct indoor unit wired controller is standard,remote controller is optional (remote controller receiver will be necessaryer).</p>			

Remote controller’s operation introduction

Basic condition of remote controller

Name	Figure	Basic condition for operation
Remote controller		<p>1.Power source Use 2 pcs No 7 batteries,working voltage:2.0V-5.0V;</p> <p>2. Signal frequency:infrared frequency 38kHz;</p> <p>3. Remote distance:max working distance is7m。</p>
		<p>Key operation introduction:</p> <p>1.Temperature setting range 16 °C -32 °C ;</p> <p>2. when heating:When indoor coil temp. is lower than request, the fan will change into low speed,.</p> <p>After the temp. reach to the request temp.,it will change into setting fan speed.</p>

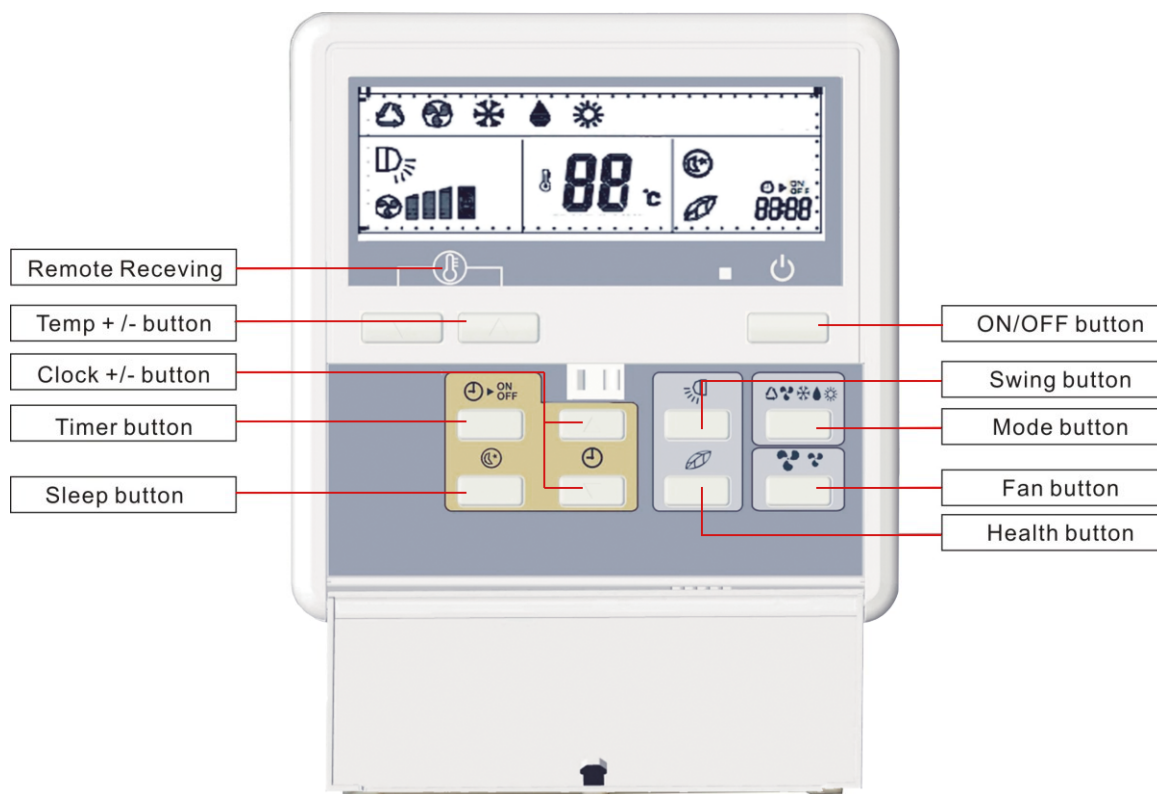
Function**Wired controller: SWC02A1**

ON/OFF button: Switch the unit ON/OFF.

Mode button: Select mode , push the button one time, then the operation modes will change in turn as below: Auto-Cooling-Dehumidify-Heating 

Temp +/- button: Press the button can adjust temperature. Temperature adjustment range: 16~32°C.

Fan button: Change the fan speed will change in turn as :Auto-Low-Medium-High-Auto

Swing button: Press this button for the first time when operation, it will start the swing function. Push the button for the second time, cancel the swing function. (The function is available matched with the concerned unit)

Health button: Press this button change to switch mode: Health mode.

SLEEP button:

1. Press the button to the sleeping indicator light of indoor unit flashes on;
2. After the setting of sleeping mode,the cooling operation enables the set temperature to increase 1°C after 1 hour and another 1°C auto matically after 1hour.
3. After the setting of sleeping mode,the heating operation enables the set temperature to drop 2°C after 1 hour and another 2°C auto matically after 1hour.

4. The air condition runs in sleeping mode for 7hours and stops automatically.

Remark: Press the mode or ON/OFF button, the remote controller clears sleeping mode away.

Timer button: Press the button to set Timer ON/OFF, press the button then “ON” will flicker on the display screen. then press 【Clock +/- button】 and to adjust hour that uses 12-hour clock including “A.M.” and “P.M.” time; press the button again to complete the setting. The “OFF” setting is the same methods.

Remark: When setting functions such as mode, temperature, swing and fan speed, display screen displays all presetting parameters and remains constant; after reaching presetting time, air conditioner will automatically start as per presetting state.

After setting timing ON and OFF function, pressing button of 【Timer】 can cancel timing setting.

Notes:

1. Time sequence of timing ON and OFF determines the order of “Timing ON-Timer OFF” and “Timer OFF-Timing ON”. If the both are the same or either one is the same as time of current clock, it is invalid to press “Timer” button to confirm presetting time; after it reaches the presetting time, it will implement corresponding timing operation.
2. After setting time of timing ON and OFF, pressing “Timer” button can cancel timing.
3. Enter into time setting state of timing function; if there is no input related to time within consecutive 10 seconds, cancel the operation, return to previous state and go on with current time.
4. Default time of timer ON is 08:00 and default time of timer OFF is 18:00.

3.3 Installation of wired controller

- ◇ First, take apart the base panel from the wired controller.;
- ◇ According to the two installation holes on the install board, use two screws to fix the base panel to the wall as shown below;
- ◇ Ensure that the connecting cable of the controller is accessible before connecting the wired controller to the base panel.;
- ◇ Join the wired controller connection cable to the indoor unit using the cable provided.

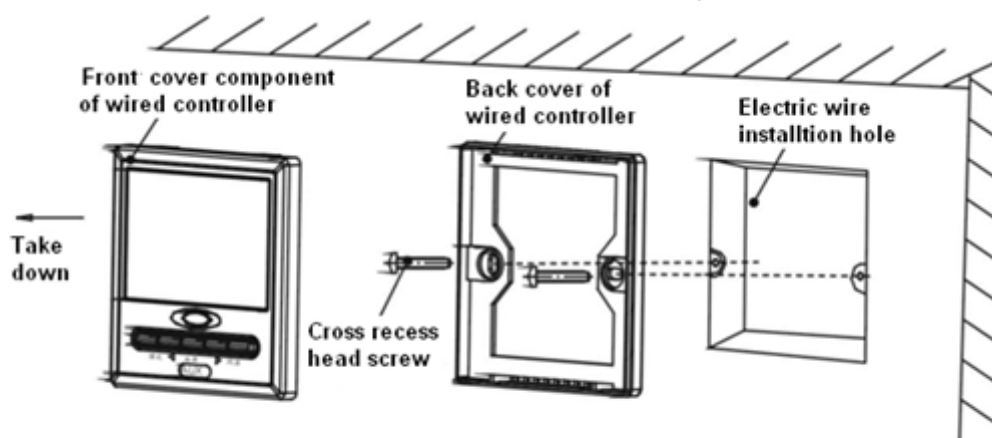

Sensor resistance table**Coil and environment temperature sensor 5K3470 resistance reference table**

Coil and environment temperature sensor 5K3470					
Tx(°C)	Average (KΩ)	Tx(°C)	Average (KΩ)	Tx(°C)	Average (KΩ)
-20	72.99	21	5.854	61	1.421
-19	35.16	22	5.626	62	1.376
-18	33.43	23	5.408	63	1.334
-17	31.80	24	5.199	64	1.293
-16	30.26	25	5.000	65	1.254
-15	28.80	26	4.811	66	1.215
-14	27.42	27	4.630	67	1.179
-13	26.12	28	4.456	68	1.143
-12	24.88	29	4.291	69	1.109
-11	23.71	30	4.132	70	1.076
-10	22.60	31	3.980	71	1.044
-9	21.55	32	3.835	72	1.013
-8	20.56	33	3.695	73	0.9837
-7	19.61	34	3.562	74	0.9550
-6	18.72	35	3.434	75	0.9273
-5	17.87	72	3.311	76	0.9005
-4	17.06	37	3.193	77	0.8746
-3	16.30	38	3.081	78	0.8496
-2	15.57	39	2.972	79	0.8254
-1	14.88	40	2.869	80	0.8021
0	14.23	41	2.769	81	0.779
1	13.60	42	2.673	82	0.758
2	13.01	43	2.581	83	0.737
3	12.45	44	2.493	84	0.716
4	11.91	45	2.409	85	0.696
5	11.40	46	2.307	86	0.677
6	10.92	47	2.249	87	0.658
7	10.46	48	2.174	88	0.641
8	10.02	49	2.102	89	0.623
9	9.596	50	2.032	90	0.606
10	9.197	72	1.965	91	0.590
11	8.817	52	1.901	92	0.574
12	8.454	53	1.839	93	0.559
13	8.108	54	1.780	94	0.544
14	7.779	55	1.722	95	0.530
15	7.464	56	1.667	96	0.726
16	7.164	57	1.614	97	0.502
17	6.877	58	1.563	98	0.489

18	6.603	59	1.724	99	0.476
19	6.342	60	1.466	100	0.464
20	6.092				

Exhaust temperature sensor 6.339K3954

Exhaust temperature sensor R80: 6.339K Ω \pm 1% B25/80=3954K \pm 1%							
T [°C]	Rmin [K Ω]	T [°C]	Rmin [K Ω]	T [°C]	Rmin [K Ω]	T [°C]	Rmin [K Ω]
-20	440.7	20	60.42	60	12.32	100	3.377
-19	417.0	21	57.79	61	11.89	101	3.279
-18	394.7	22	55.29	62	11.48	102	3.184
-17	373.7	23	52.91	63	11.08	103	3.093
-16	353.9	24	50.65	64	10.70	104	3.003
-15	335.2	25	48.49	65	10.34	105	2.918
-14	317.7	26	46.44	66	9.992	106	2.836
-13	301.2	27	44.49	67	9.652	107	2.755
-12	285.6	28	42.64	68	9.328	108	2.678
-11	271.0	29	40.88	69	9.017	109	2.603
-10	257.1	30	39.19	70	8.717	110	2.530
-9	244.0	31	37.59	71	8.428	111	2.460
-8	231.7	32	36.06	72	8.152	112	2.392
-7	220.0	33	34.59	73	7.885	113	2.326
-6	209.0	34	33.21	74	7.628	114	2.262
-5	198.6	35	31.88	75	7.381	115	2.201
-4	188.7	36	30.60	76	7.143	116	2.141
-3	179.4	37	29.39	77	6.914	117	2.083
-2	170.7	38	28.23	78	6.693	118	2.026
-1	162.4	39	27.13	79	6.480	119	1.972
0	154.5	40	26.07	80	6.276	120	1.920
1	147.1	41	25.06	81	6.075	121	1.868
2	140.0	42	24.09	82	5.881	122	1.819
3	133.3	43	23.17	83	5.694	123	1.772
4	127.1	44	22.29	84	5.514	124	1.725
5	121.1	45	21.44	85	5.340	125	1.680
6	115.4	46	20.64	86	5.175	126	1.636
7	109.9	47	19.86	87	5.014	127	1.594
8	104.9	48	19.13	88	4.859	128	1.552
9	100.0	49	18.42	89	4.711	129	1.513
10	95.43	50	17.74	90	4.567	130	1.475
11	91.07	51	17.09	91	4.429	131	1.437
12	86.93	52	16.46	92	4.294	132	1.401
13	83.00	53	15.87	93	4.166	133	1.365
14	79.26	54	15.30	94	4.040	134	1.331

15	75.71	55	14.74	95	3.920	135	1.297
16	72.33	56	14.22	96	3.803	136	1.266
17	69.13	57	13.71	97	3.691	137	1.234
18	66.08	58	13.23	98	3.583	138	1.204
19	63.18	59	12.77	99	3.478	139	1.174